

Readme for Scratchbuilt AR15 Receiver Blueprints

By elmgrove1765@yahoo.com

1. Release Dates

June 2002: Scratchbuilt AR15 receiver project completed and test fired

Oct 2002-Mar 2003: Incremental release of readme.txt and all 11 parts blueprints:

- sideleft_rev_A.pdf - rxvr left side plate
- sideright_rev_A.pdf - rxvr right side plate
- fcwell_rev_A.pdf - fire control well bottom
- magfront_rev_A.pdf - magazine well front
- magleft_rev_A.pdf - magazine well left side plate
- magright_rev_A.pdf - magazine well right side plate
- magback_rev_A.pdf - magazine well back
- buffer_rev_A.pdf - buffer tube part
- bufferstop_rev_A.pdf - buffer retainer rod
- grip_rev_A.pdf - grip part
- tguard_rev_A.pdf - trigger guard

Mar 2003: Admin of "Photos and Blueprints" forum of www.roderuscustom.tzo.com combined all files into a single .pdf document with bookmarks.

24 Mar 2003: Updated two blueprints due to email feedback from users
Receiver left side plate (rev. B) - added missing 'X' positions of trigger/hammer pin holes, suppressed hidden lines on one sheet for clarity
Receiver right side plate (rev. B) - added missing 'X' positions of trigger/hammer pin holes, suppressed hidden lines on one sheet for clarity

24 Apr 2003: Updated two blueprints due to additional email feedback from users
Receiver right side plate (rev. C) - added missing 'Y' position of mag. release button hole
Grip (rev. B) - added missing dimensions to locate 30 deg. angle for pistol grip

Note: "left" and "right" refer to the user's point of view when the rifle is held in the normal firing position.

2. Links

For more information or photos please see:

Webpage: <http://www.geocities.com/elmgrove1765> (See link for "P6: AR15 receiver")

Photo albums: http://community.webshots.com/user/user_556

3. Decimal inch cross reference

All blueprint dimensions are in decimal inches. Here are some of the less common decimal inch equivalents that were used during machining (for drill sizes, end mill diameters, etc.)

0.0890" -> use #43 (drill size)
0.1065" -> use #36 (drill size)
0.1094" -> use 7/64"
0.1360" -> use #29 (drill size)
0.1563" -> use 5/32" (radius of 5/16" diameter)
0.2031" -> use 13/64"
0.2130" -> use #3 (drill size)

4. Notes

1) Every effort has been made to ensure the plans are correct, but in the unlikely event there is an error or if you have any suggestions, please email the author. Note that the author assumes no liability for any adverse consequences resulting from the construction or use of this AR15 receiver. Please obey all laws.

2) If you use 1/8" plate stock for the side plates, note that the actual thickness of the plate may have a tolerance of .005" or more. The actual thickness is not critical as long as the flats machined at the end of the receiver side plates has a thickness of 0.104" ([see Receiver - Left Side Sheet 3](#) and [Receiver - Right Side Sheet 5](#))

3) The only holes that should be reamed to the final diameter are the trigger and hammer pin holes – the other holes can be drilled normally. The "Colt Redraw Blueprints" by D. Snider (the most common one available on WWW) show the hammer and trigger pin holes as .1560 +/- .0015 in diameter. The blueprints show that the receiver was built using hammer/trigger pin holes of .15625" (5/32") which is a standard reamer size. This slight difference has not proven to be a problem in practice.

4) The "Colt Redraw Blueprints" by D. Snider show the magazine release button hole with a width (narrower dimension) of .318". I measured several magazine release buttons, and the max. size I found was 0.3" wide. Since a .318" endmill is an unusual size, the blueprints show that the receiver was built using a magazine release button width of 5/16" (.3125") - a standard end mill diameter. There is still more than enough slack so that the magazine release button moves easily.

5) The fire control well bottom has a thickness of 0.125" ([see Fire Control Well](#)). I got a bit lazy and used 1/8" aluminum plate "as is" without machining it to the correct thickness. The thickness of the part turned out to be 0.120" - a bit off, but still acceptable since the depth of the fire control well has a tolerance of .010" (as shown in D. Snider's print)

6) Although there is a copyright notice on the blueprints, everyone has permission to download or distribute as many copies as they want. I put the notice on the blueprints just to claim authorship. *grin* The design is in the public domain, so feel free to build it (subject to local laws, of course)

7) Ignore the revision label on each sheet (not updated). The correct print revision is in the bookmarks.

8) Have fun and be safe!

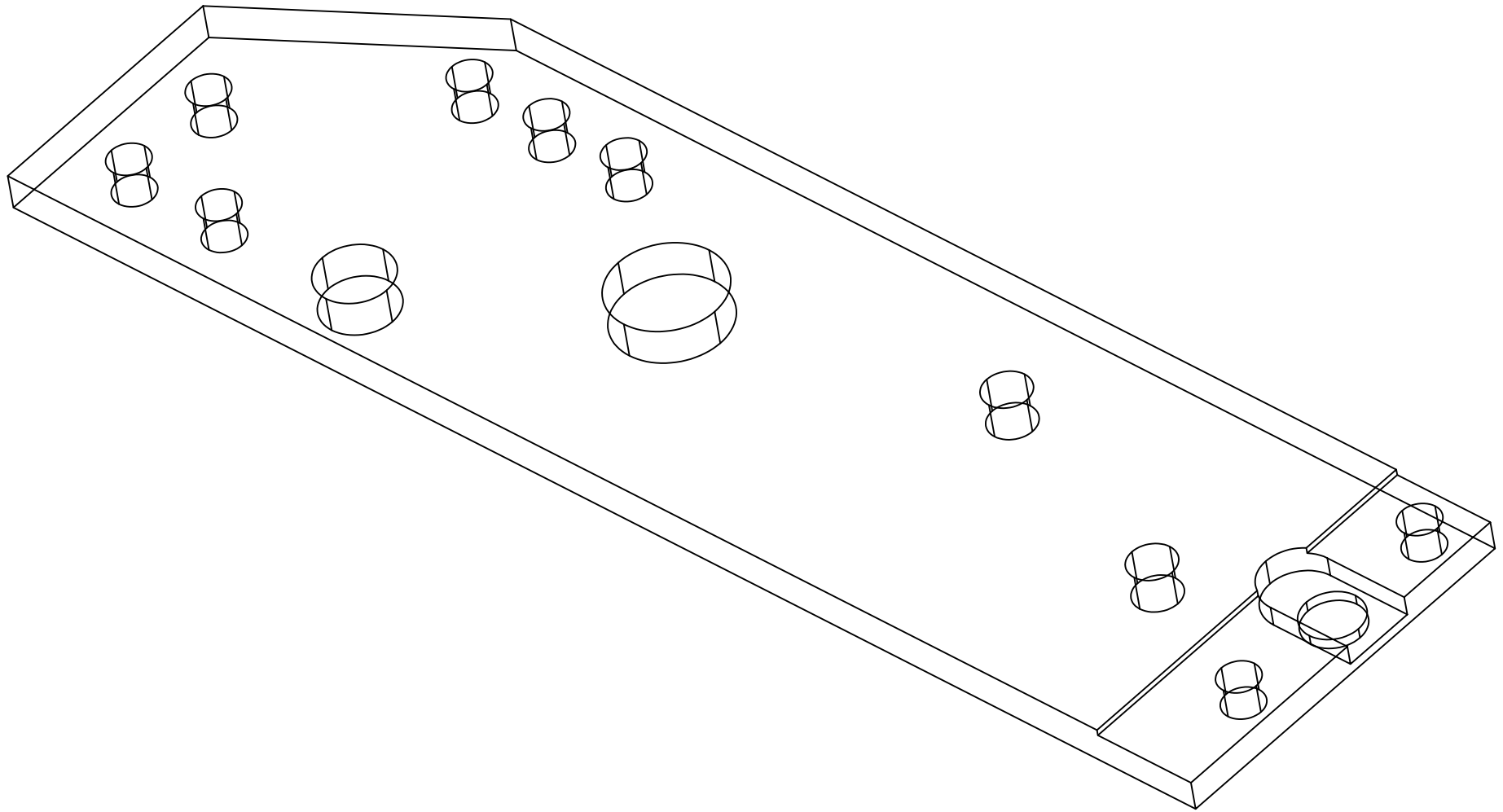

TITLE	AR15 receiver left side	DATE	Mar 2002	REV	A
AUTHOR	Copyright: elmgrove1765@yahoo.com	SHEET	0		

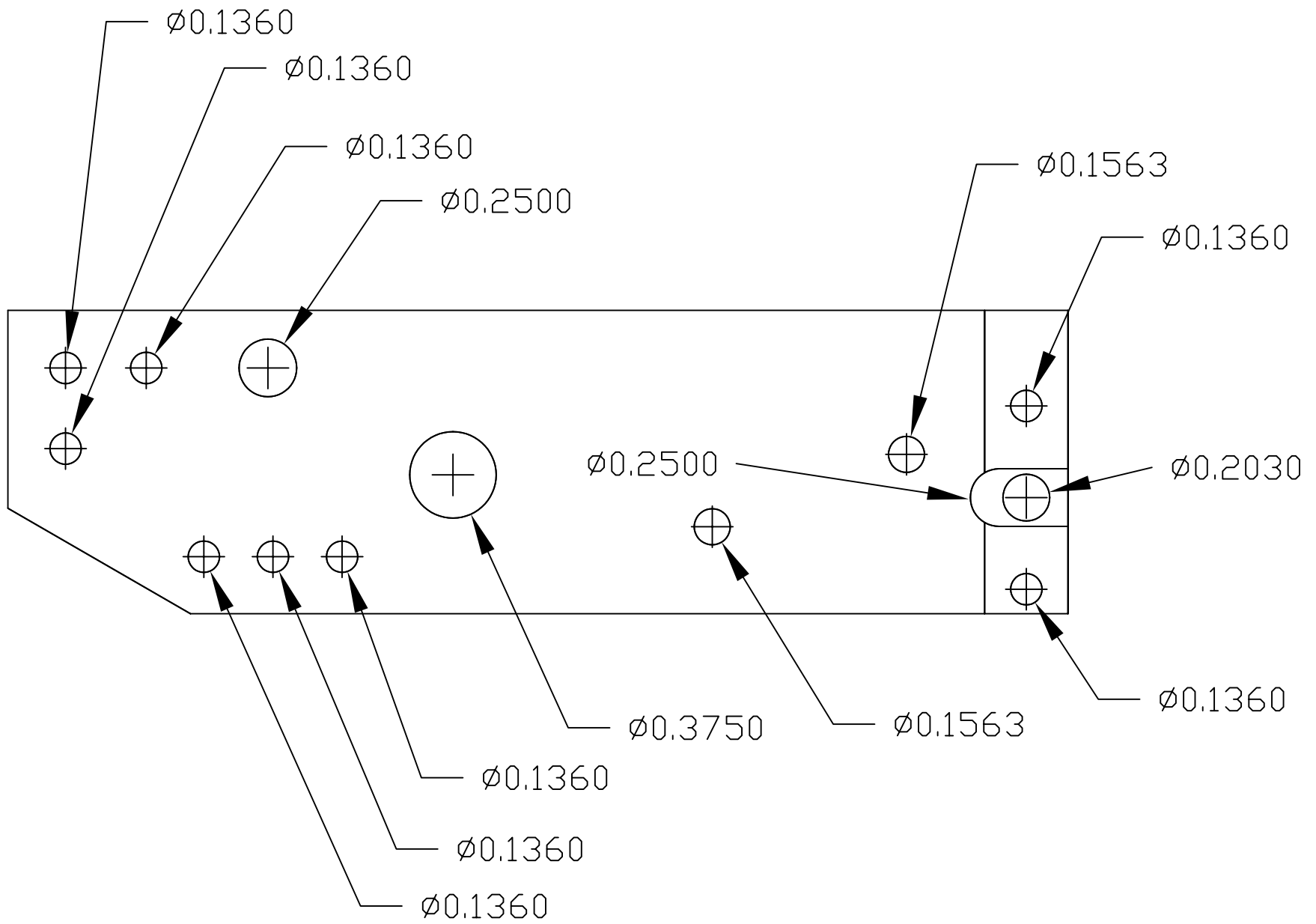

TITLE	AR15 receiver left side	DATE	Mar 2002	REV	A
AUTHOR	Copyright: elmgrove1765@yahoo.com	SHEET	1		

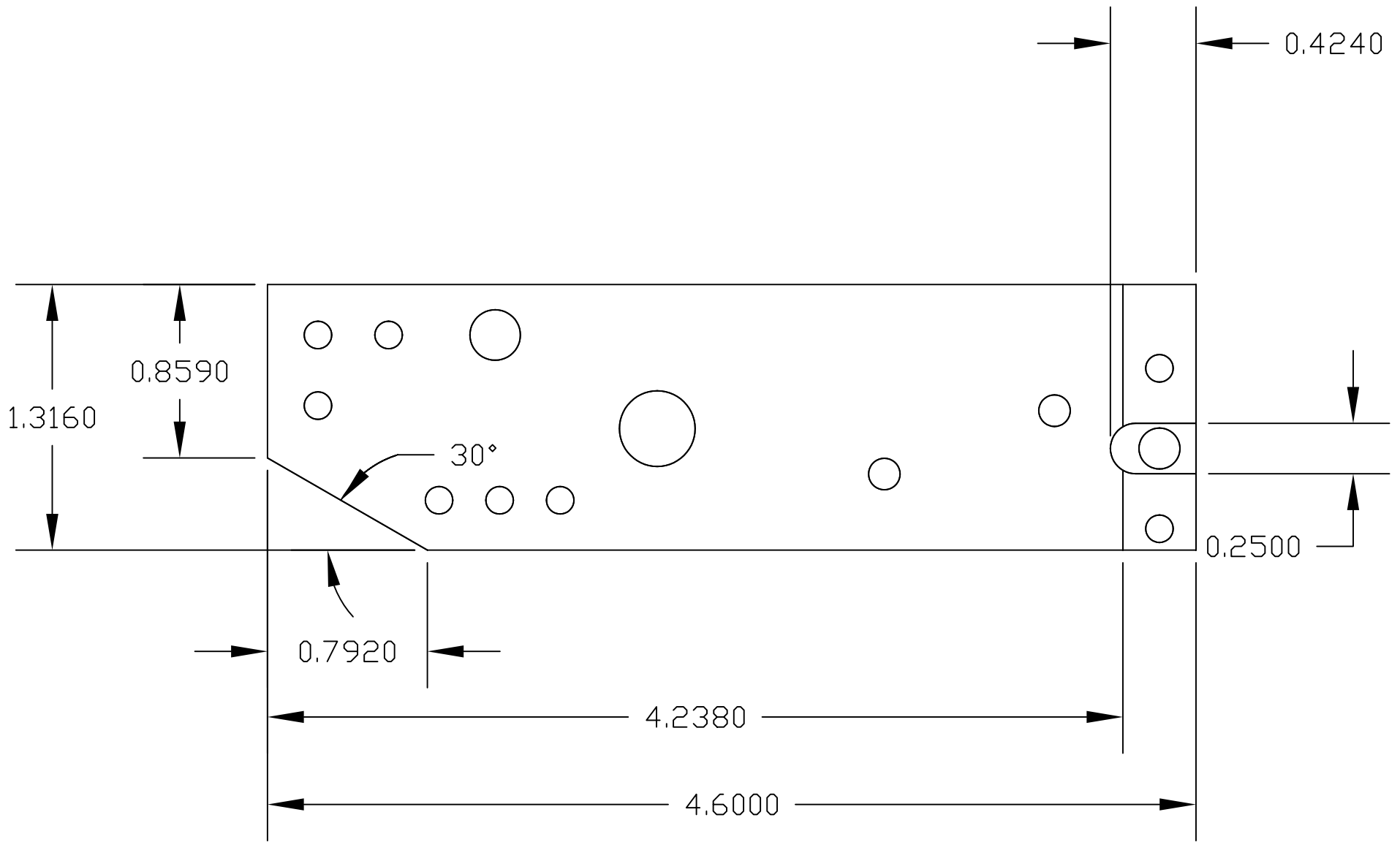

TITLE	AR15 receiver left side	DATE	Mar 2002	REV	A
AUTHOR	Copyright: elmgrove1765@yahoo.com	SHEET	2		

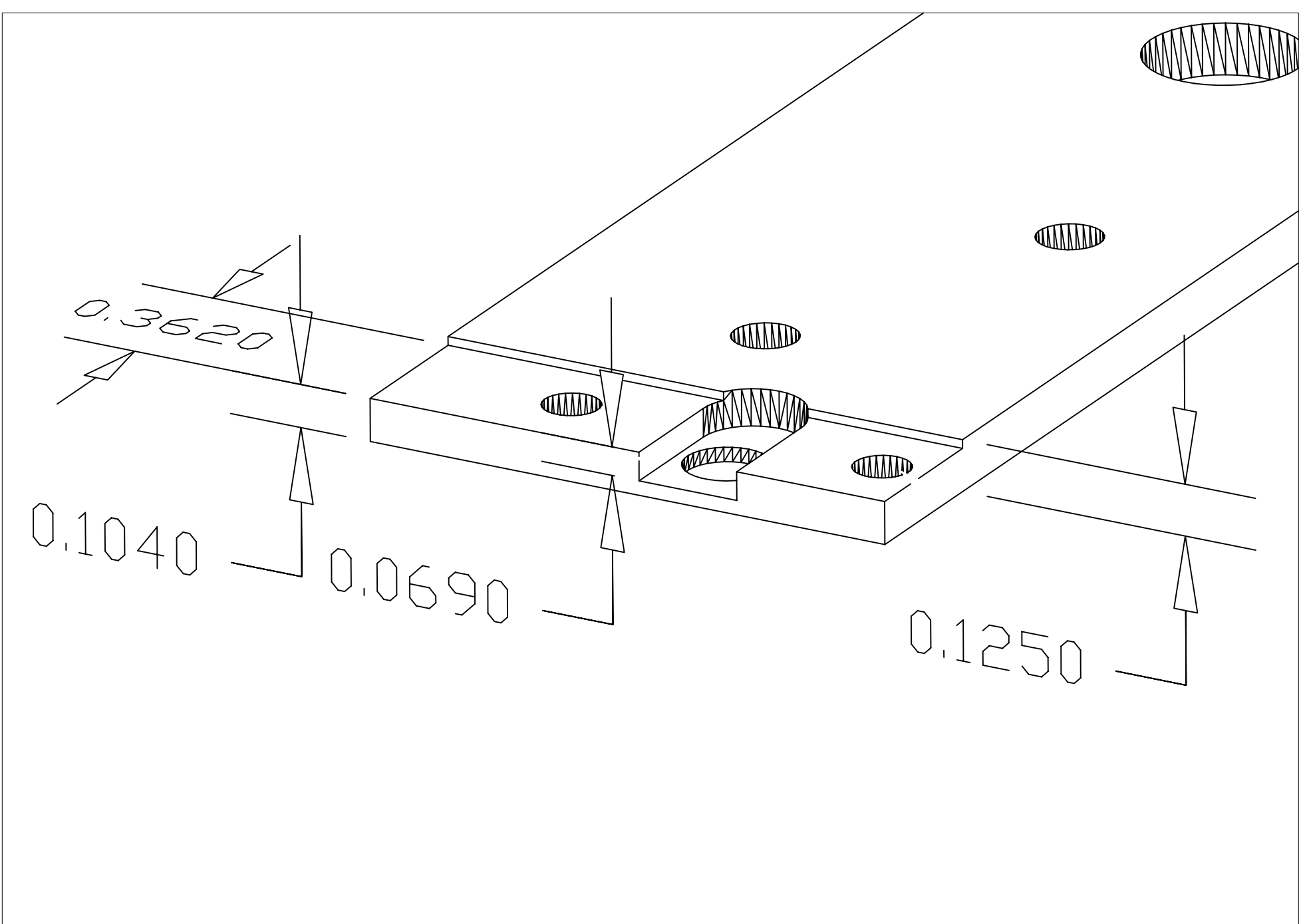

TITLE	AR15 receiver left side	DATE	Mar 2002	REV	A
AUTHOR	Copyright: elmgrove1765@yahoo.com	SHEET	3		

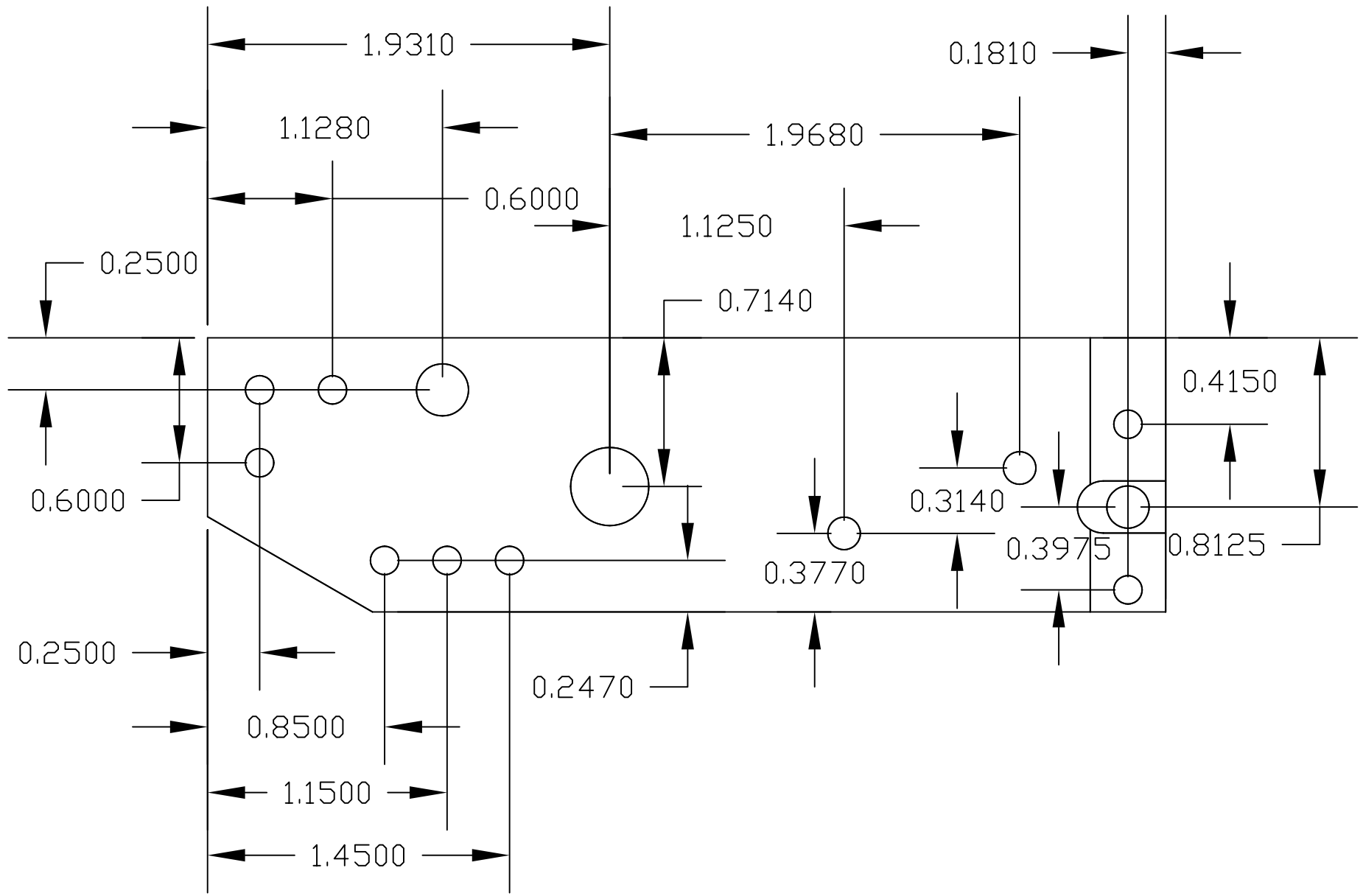

TITLE	AR15 receiver left side	DATE	Mar 2002	REV	A
AUTHOR	Copyright: elmgrove1765@yahoo.com	SHEET	4		

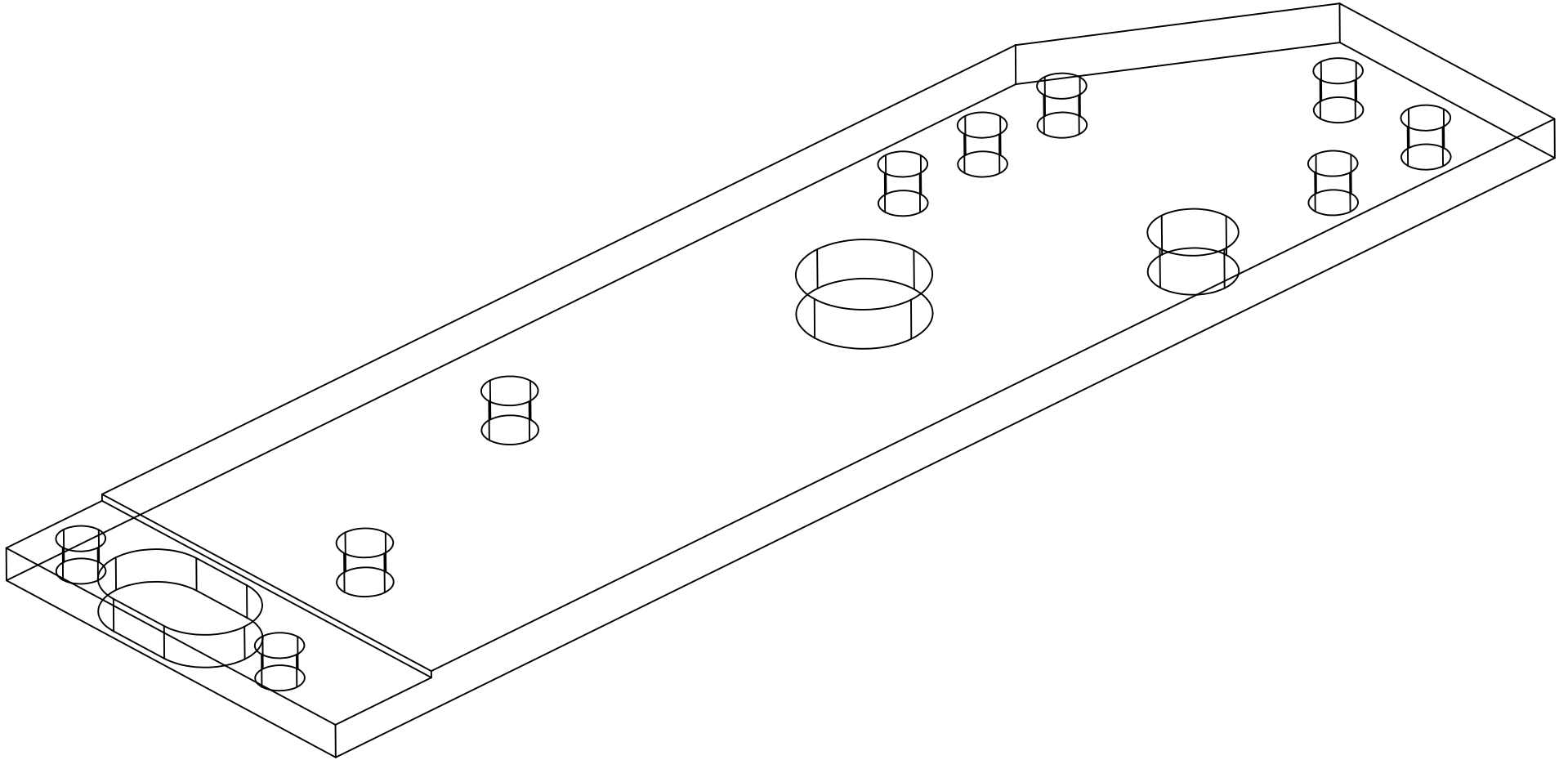

TITLE	AR15 receiver right side	DATE	Mar 2002	REV	A
AUTHOR	Copyright: elmgrove1765@yahoo.com	SHEET	0		

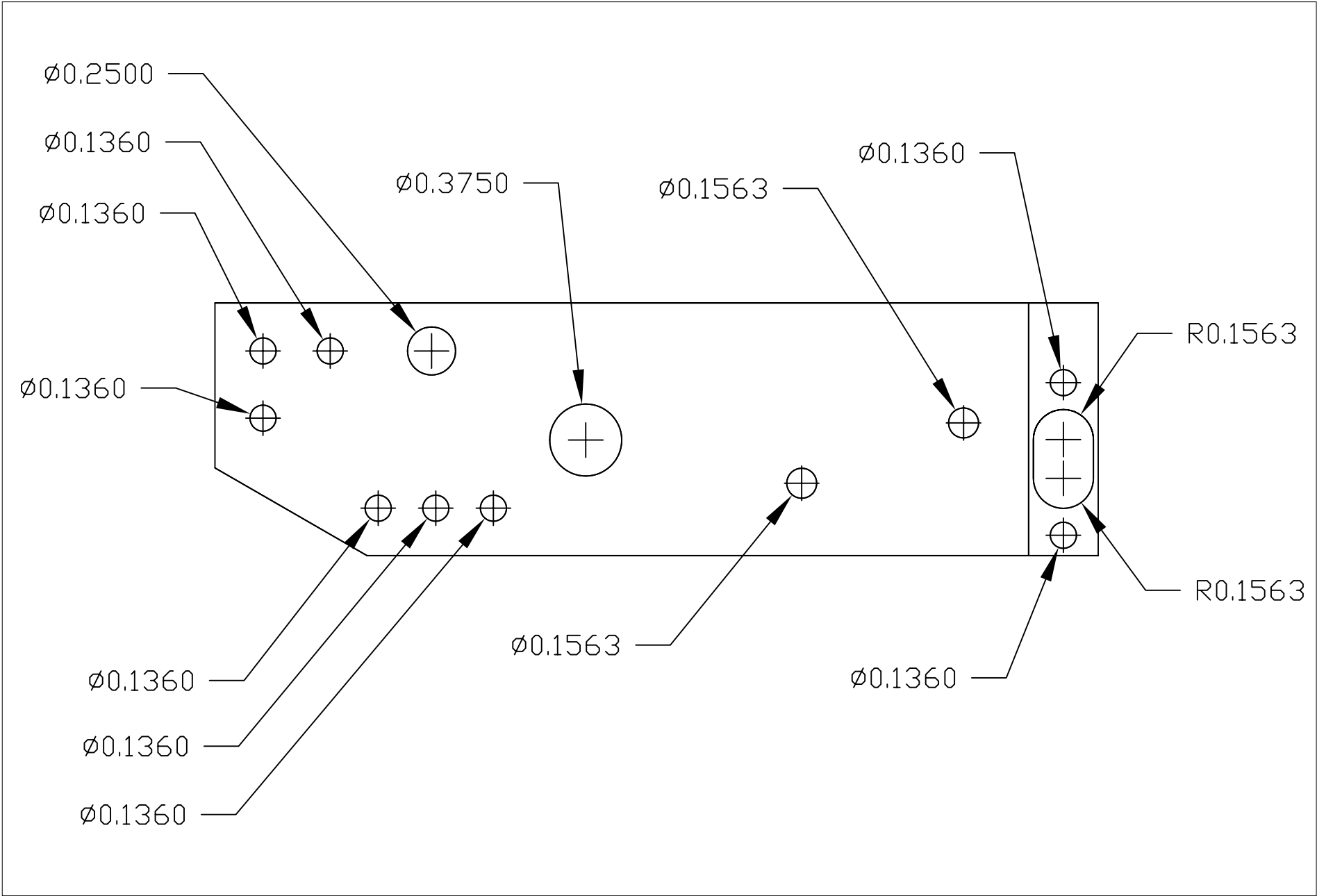

TITLE	AR15 receiver right side	DATE	Mar 2002	REV	A
AUTHOR	Copyright: elmgrove1765@yahoo.com	SHEET	1		

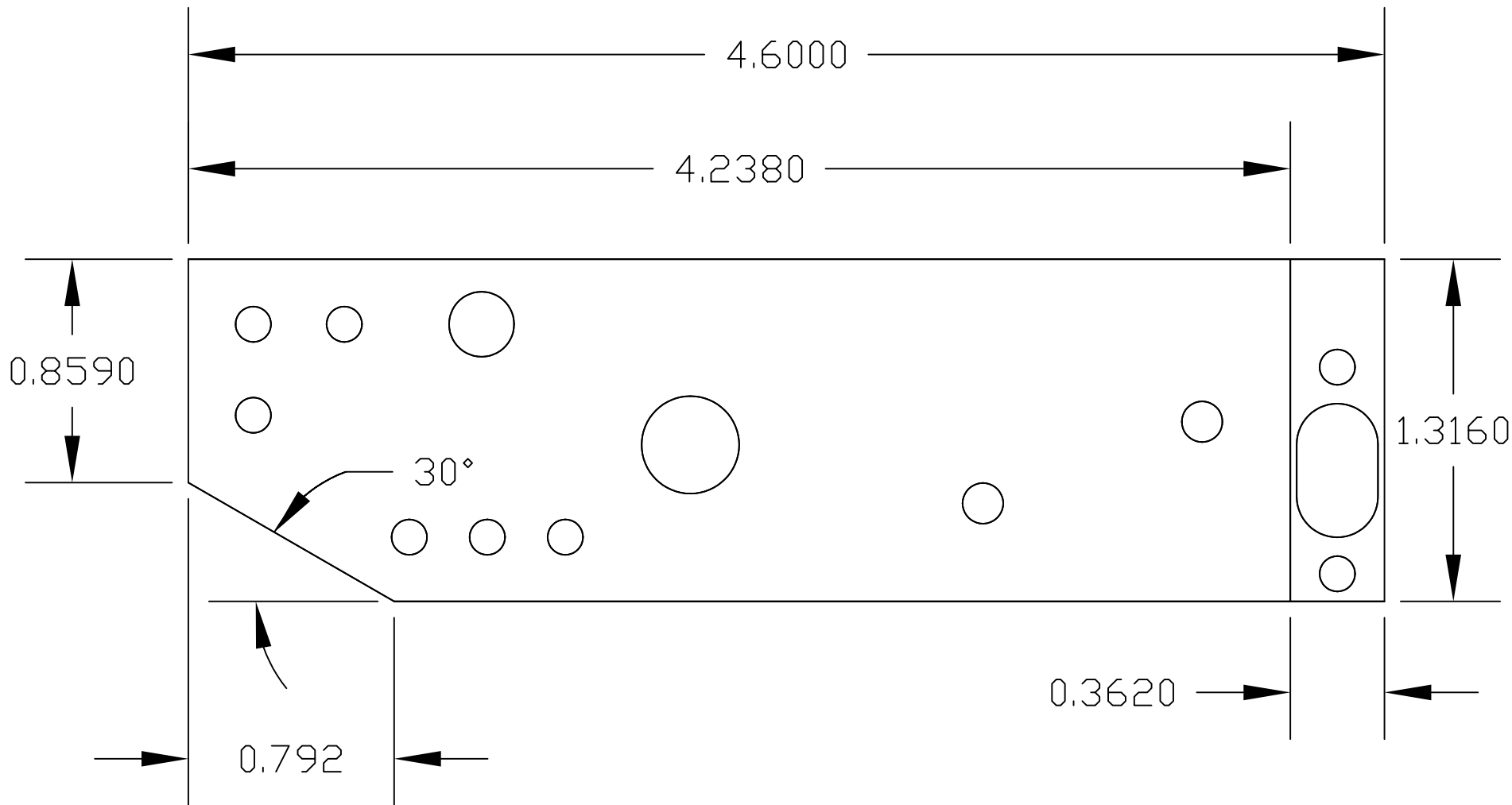

TITLE	AR15 receiver right side	DATE	Mar 2002	REV	A
AUTHOR	Copyright: elmgrove1765@yahoo.com	SHEET	2		

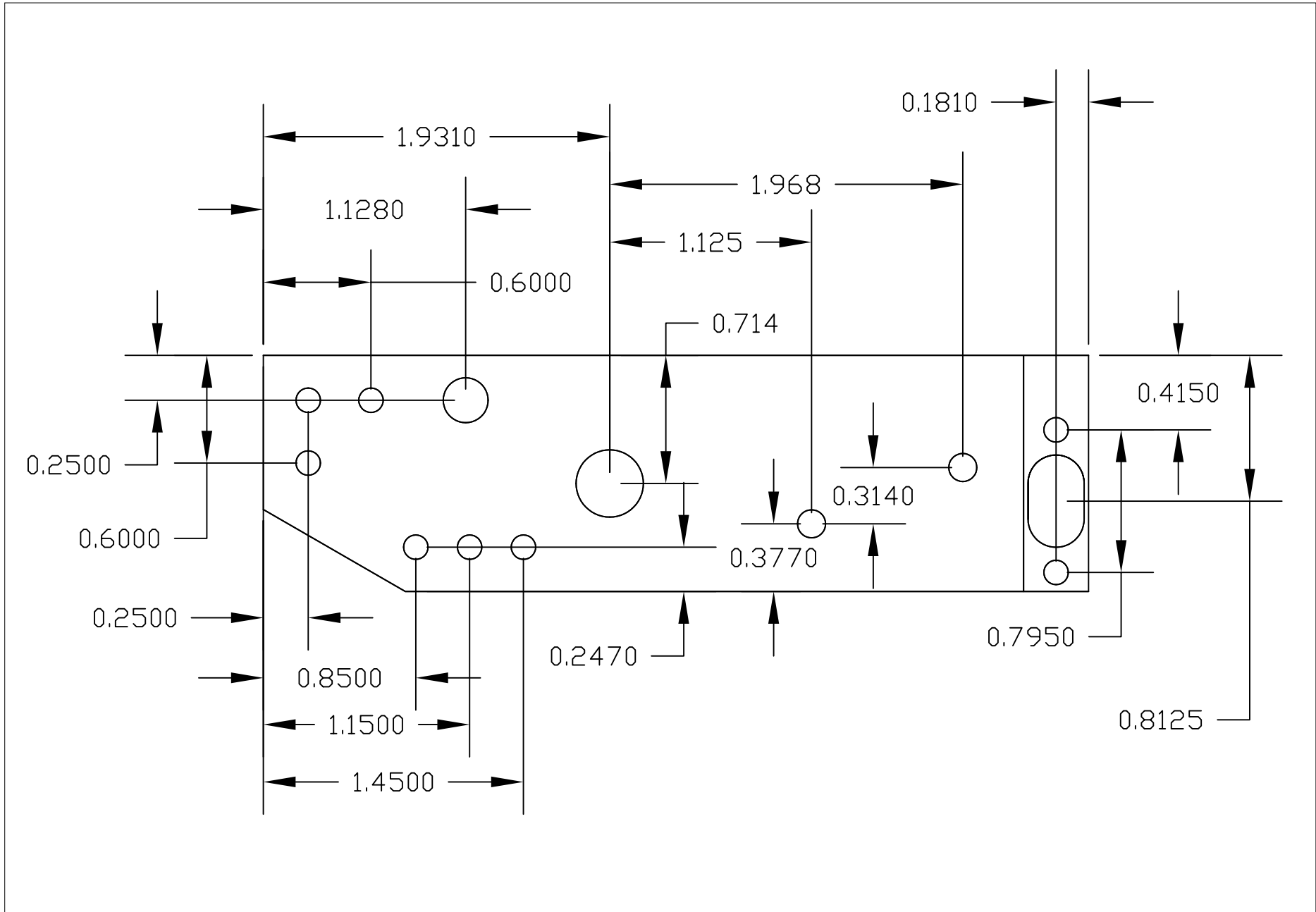

TITLE	AR15 receiver right side	DATE	Mar 2002	REV	A
AUTHOR	Copyright: elmgrove1765@yahoo.com	SHEET	3		

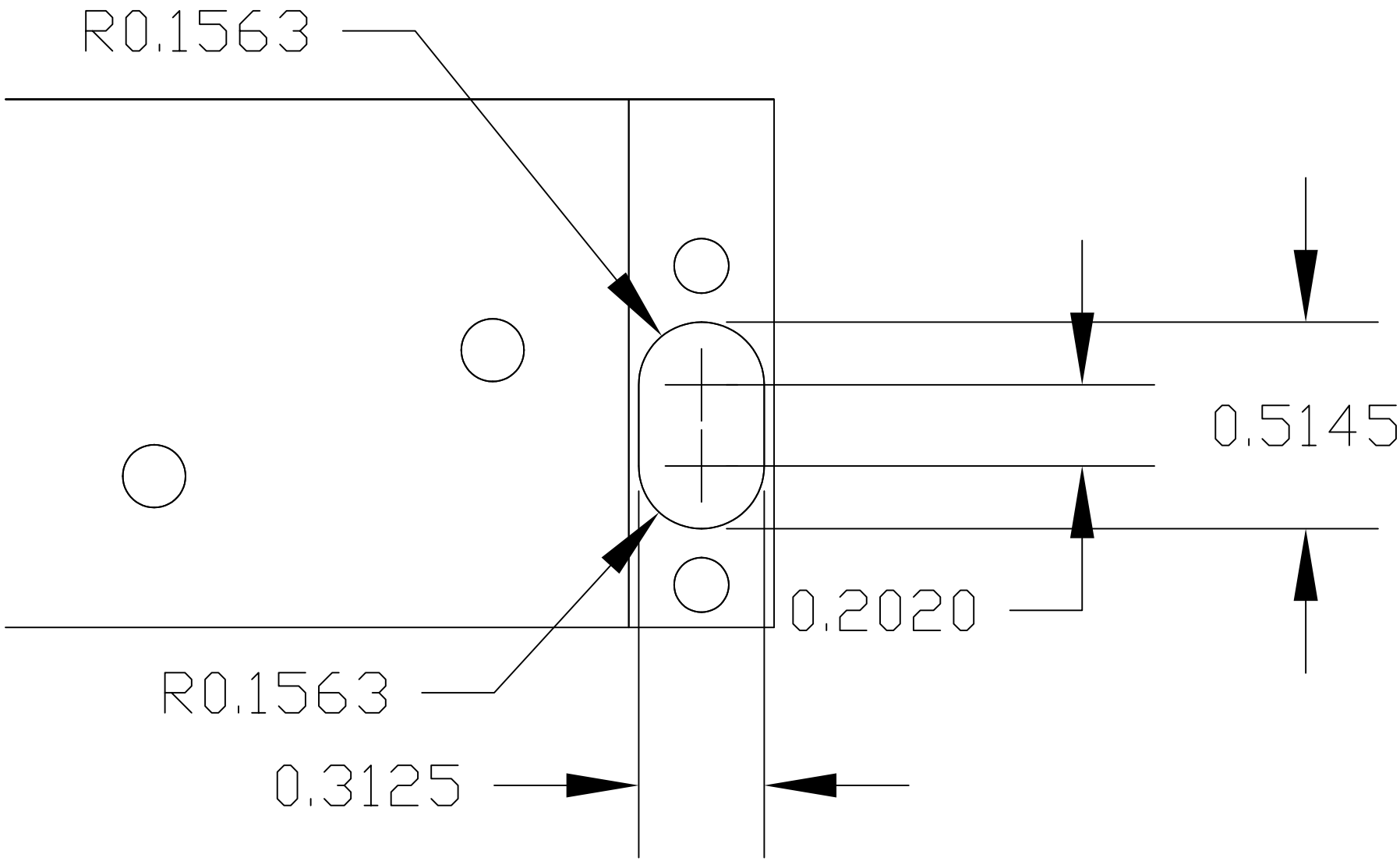

TITLE	AR15 receiver right side	DATE	Mar 2002	REV	A
AUTHOR	Copyright: elmgrove1765@yahoo.com	SHEET	4		

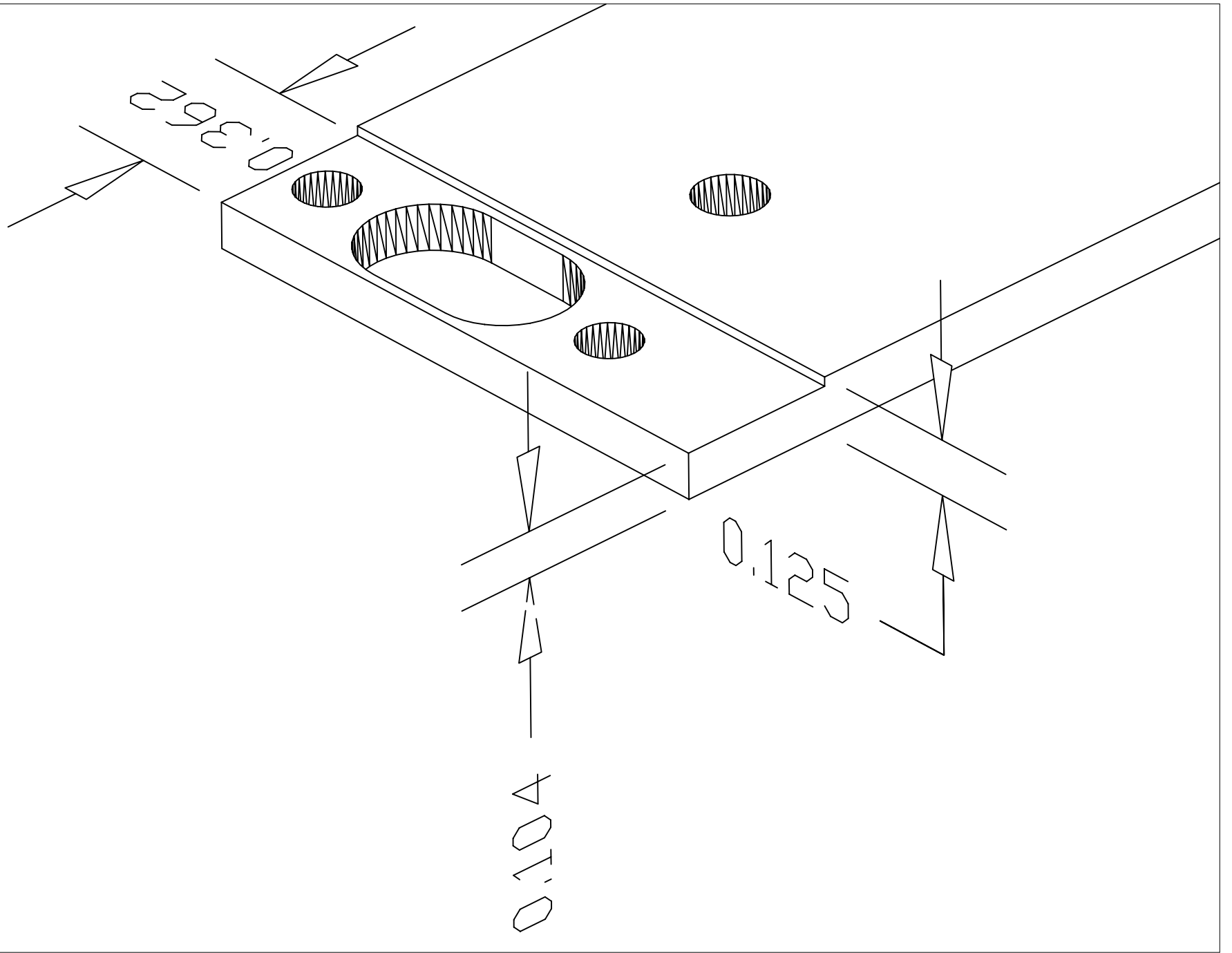

TITLE	AR15 receiver right side	DATE	Mar 2002	REV	A
AUTHOR	Copyright: elmgrove1765@yahoo.com	SHEET	5		

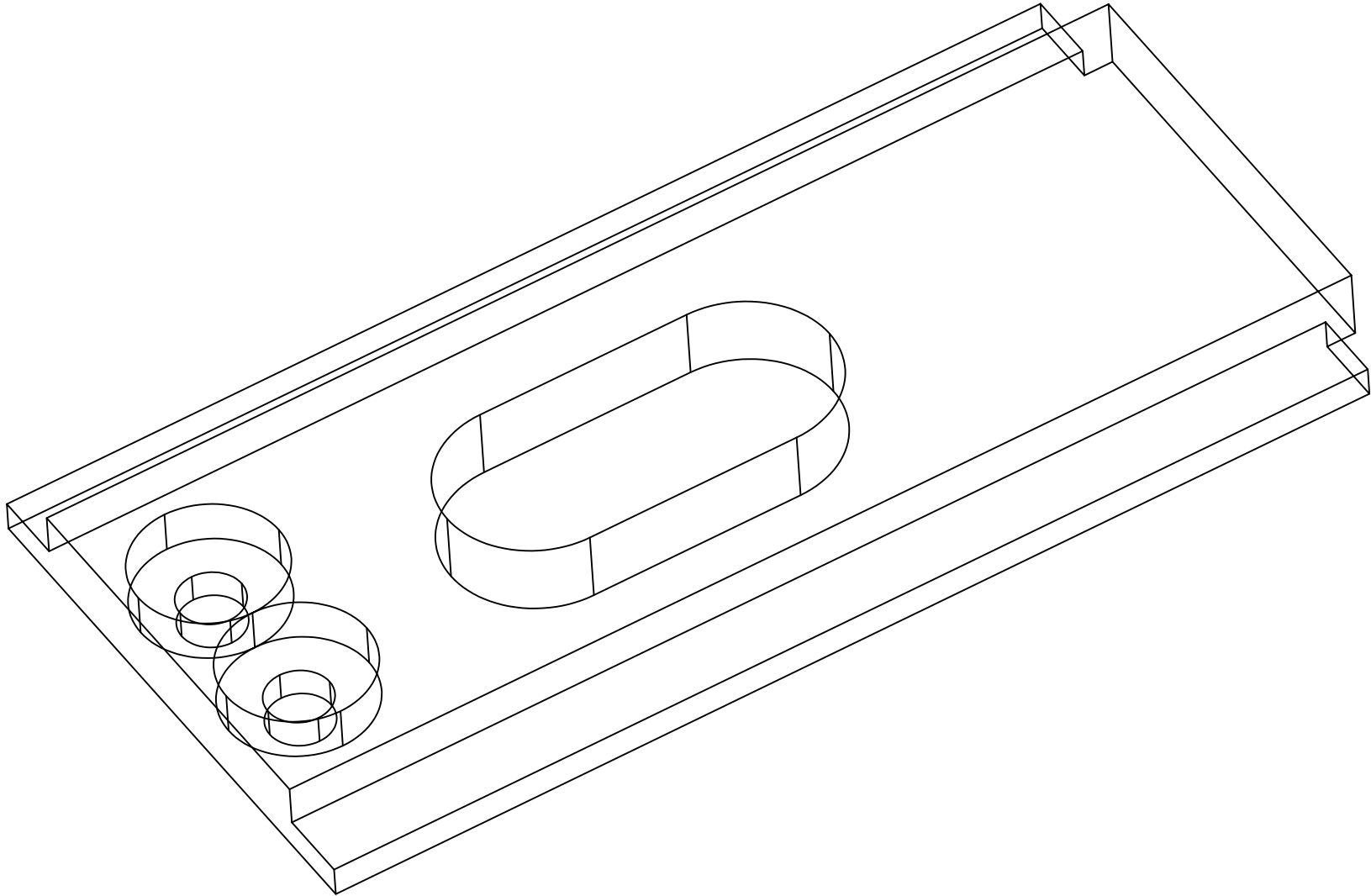

TITLE	AR15 receiver fire control well bottom	DATE	Oct 2002	REV	A
AUTHOR	Copyright: elmgrove1765@yahoo.com	SHEET	0		

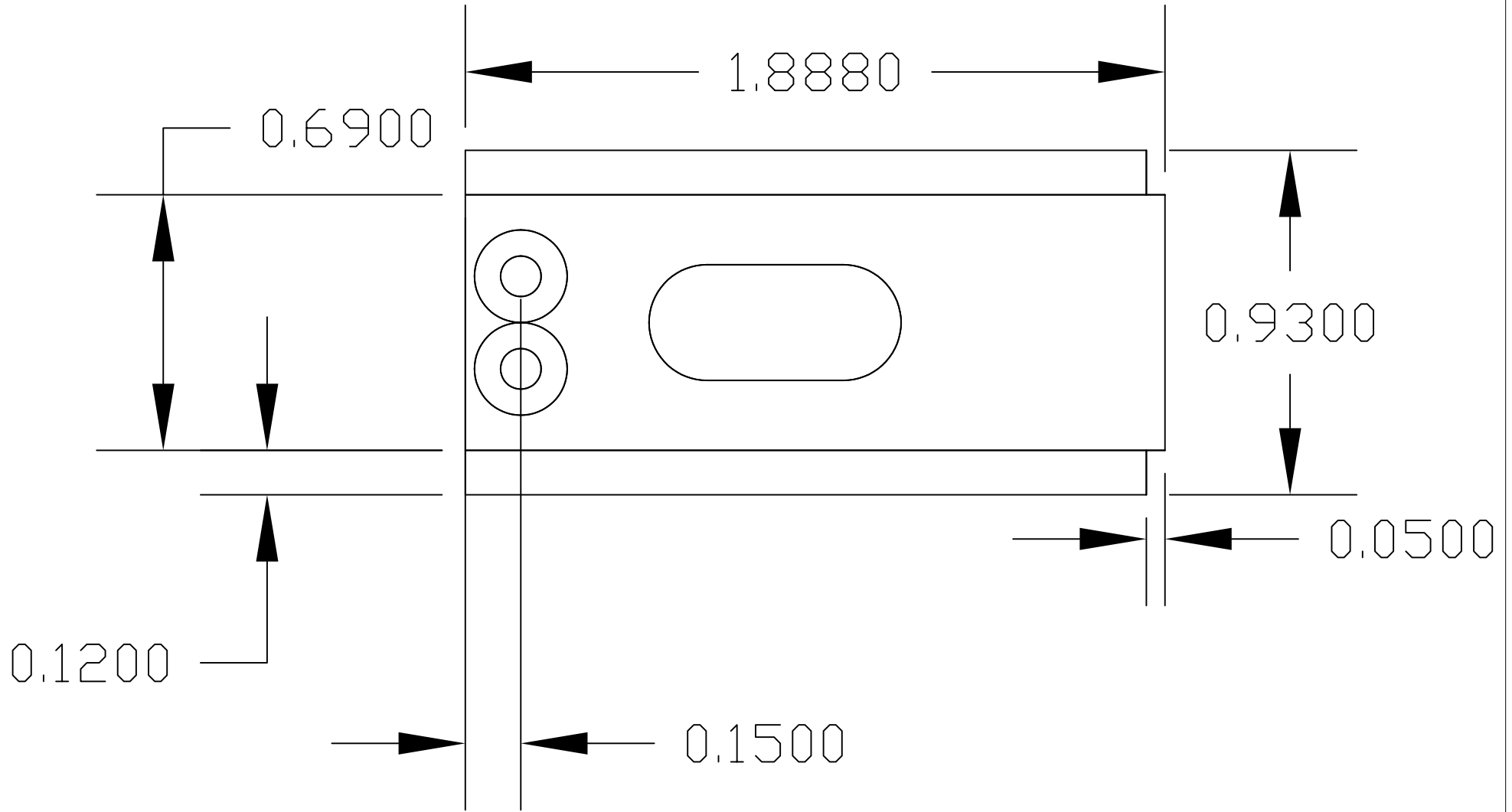

TITLE	AR15 receiver fire control well bottom	DATE	Oct 2002	REV	A
AUTHOR	Copyright: elmgrove1765@yahoo.com	SHEET	1		

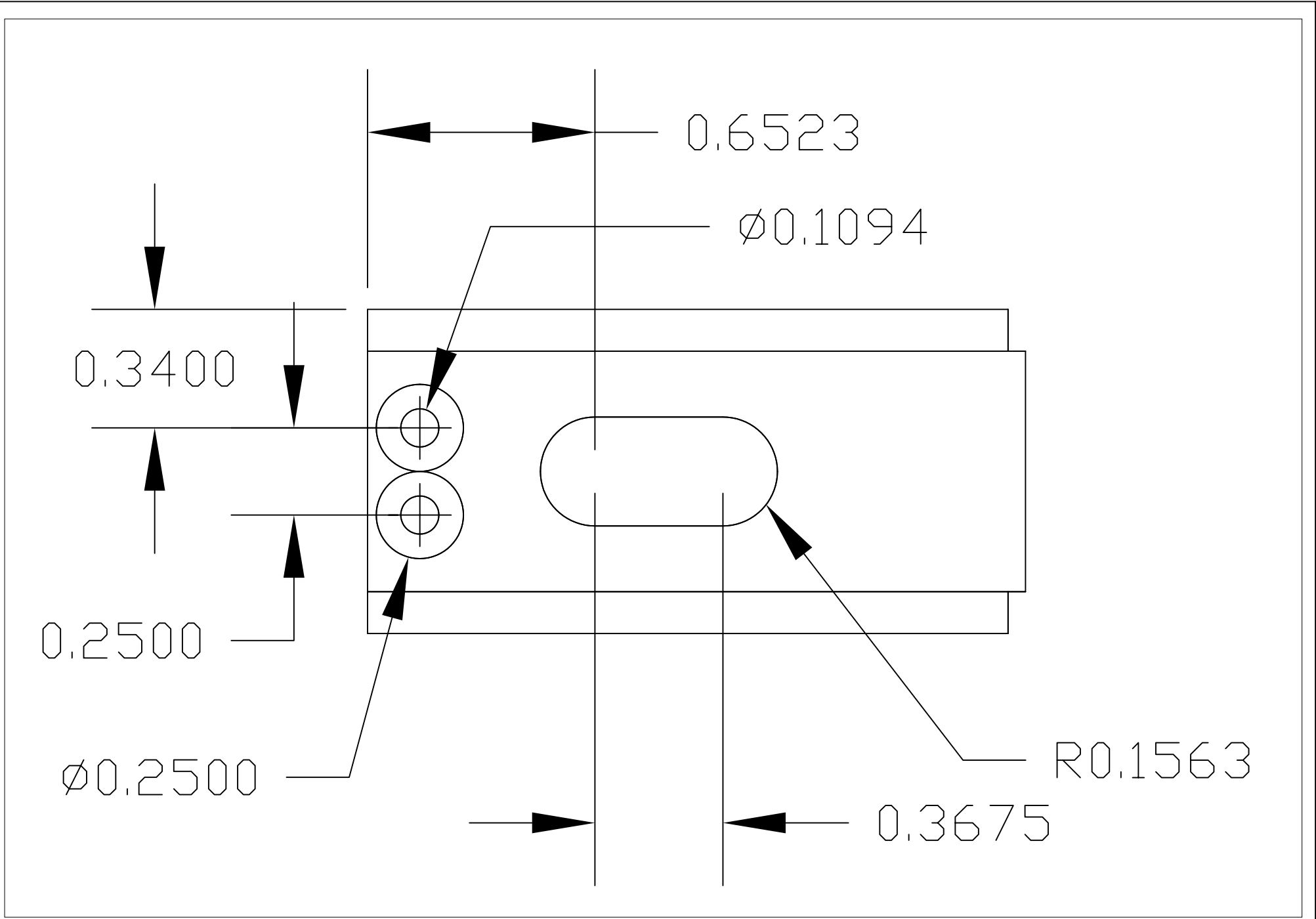

TITLE	AR15 receiver fire control well bottom	DATE	Oct 2002	REV	A
AUTHOR	Copyright: elmgrove1765@yahoo.com	SHEET	2		

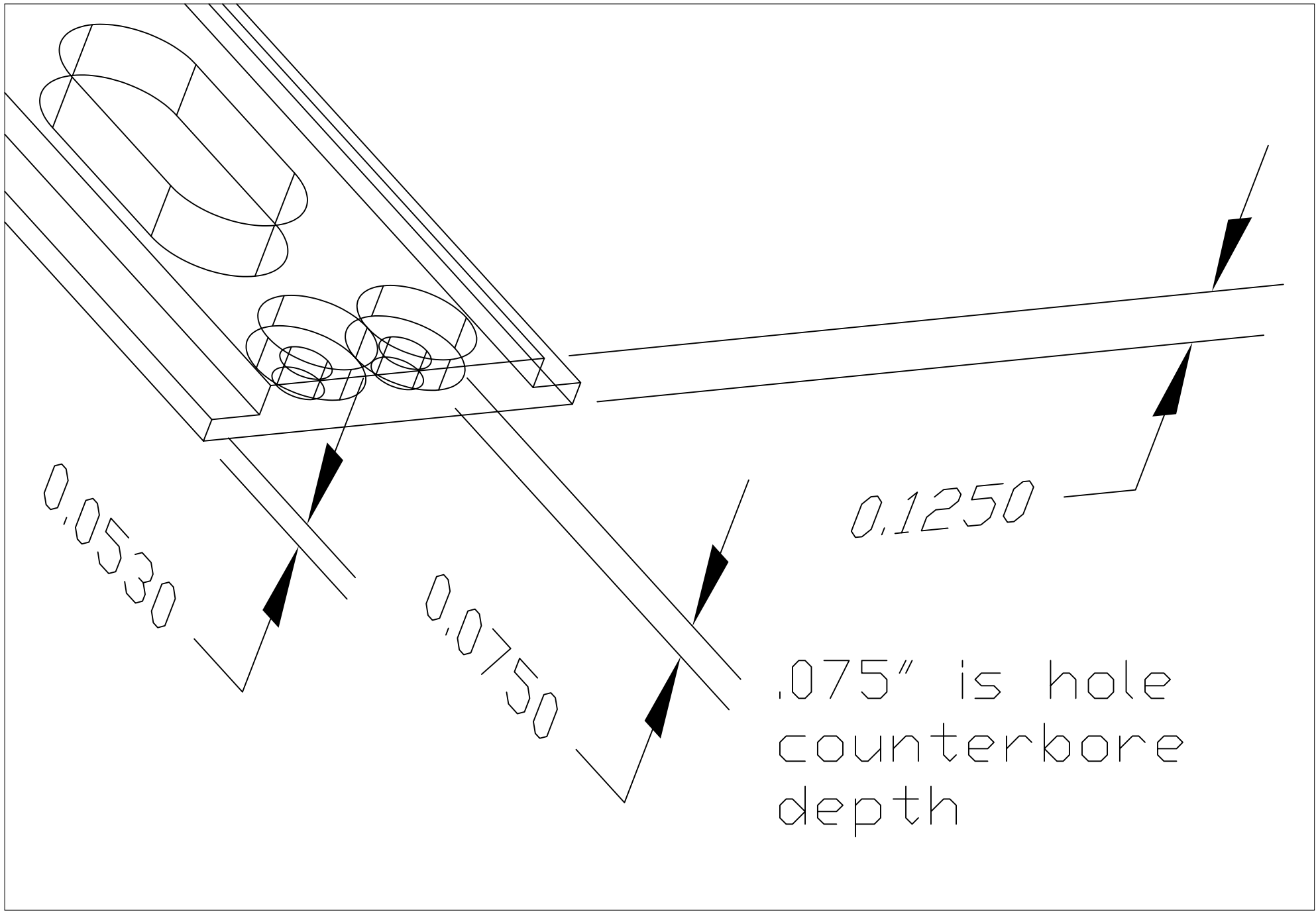

TITLE	AR15 receiver fire control well bottom	DATE	Oct 2002	REV	A
AUTHOR	Copyright: elmgrove1765@yahoo.com	SHEET	3		

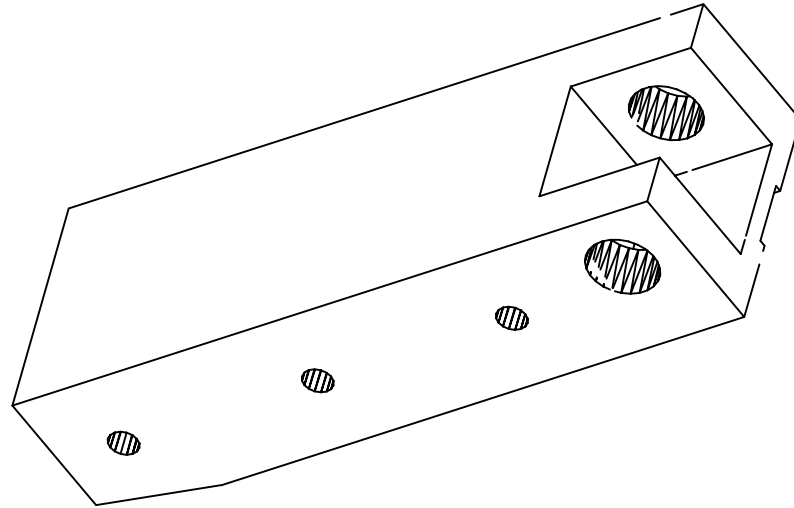
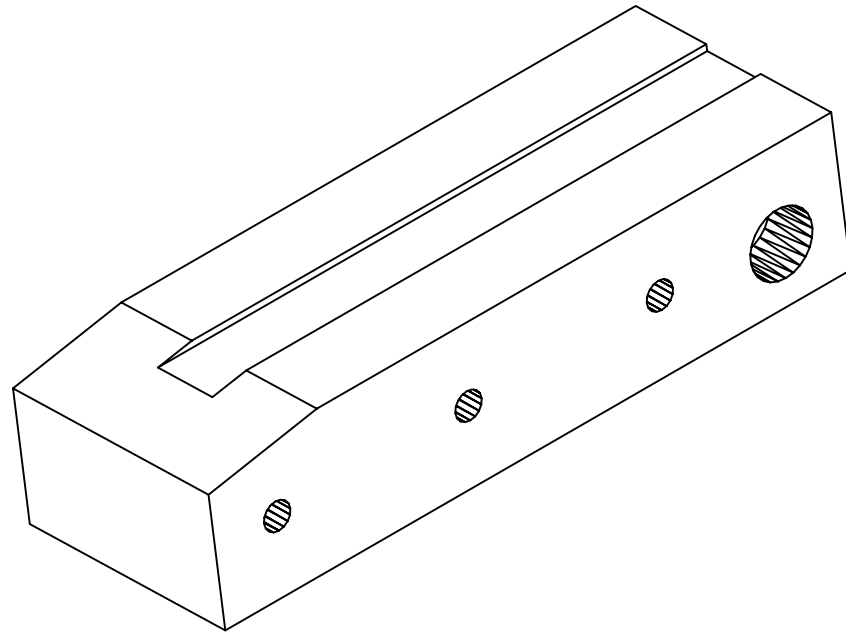

TITLE	AR15 receiver magazine well front	DATE	Nov 2002	REV	A
AUTHOR	Copyright: elmgrove1765@yahoo.com	SHEET	0		

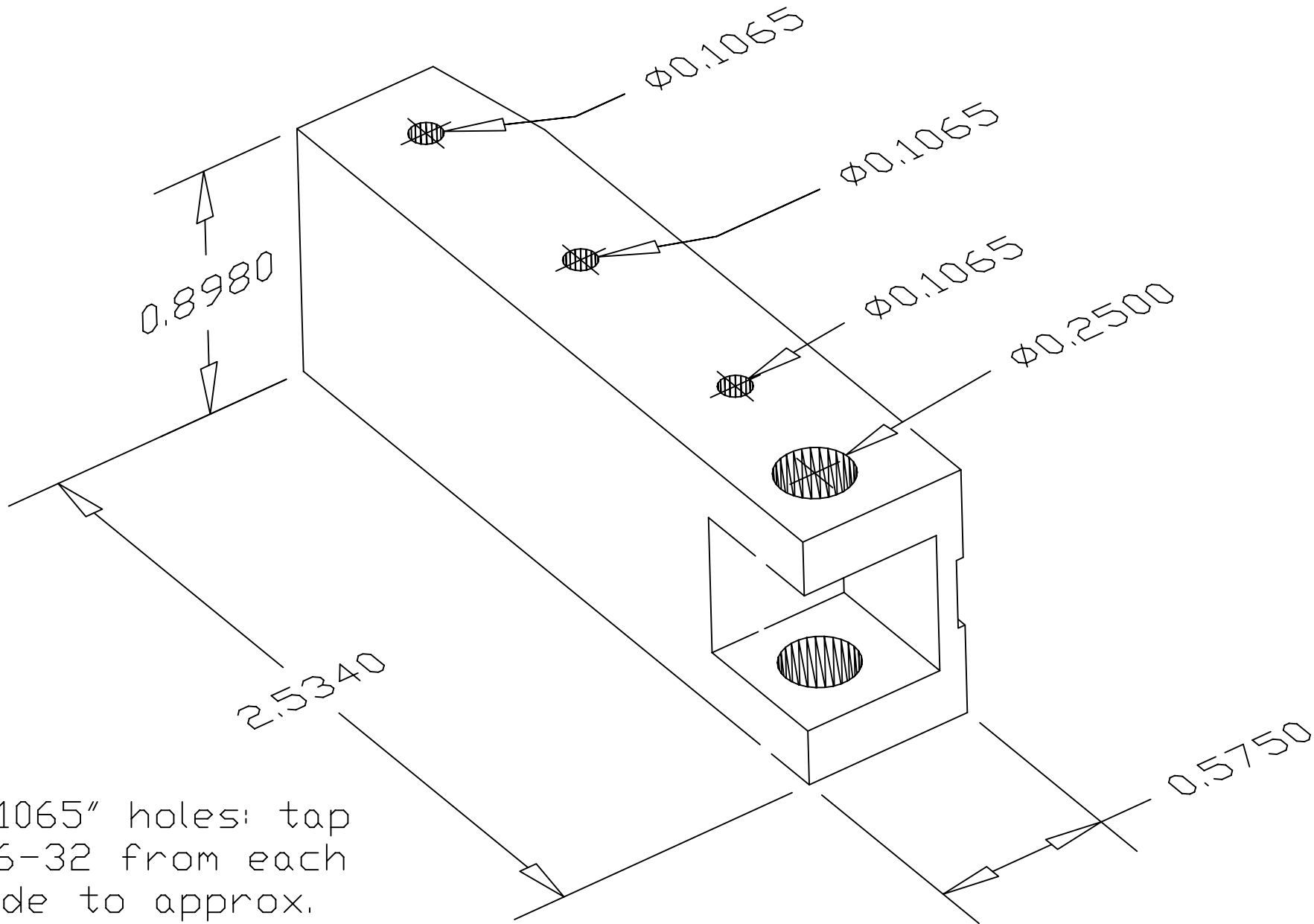

0.1065" holes: tap
 #6-32 from each
 side to approx.
 0.4" depth

TITLE	AR15 receiver magazine well front	DATE	Nov 2002	REV	A
AUTHOR	Copyright: elmgrove1765@yahoo.com	SHEET	1		

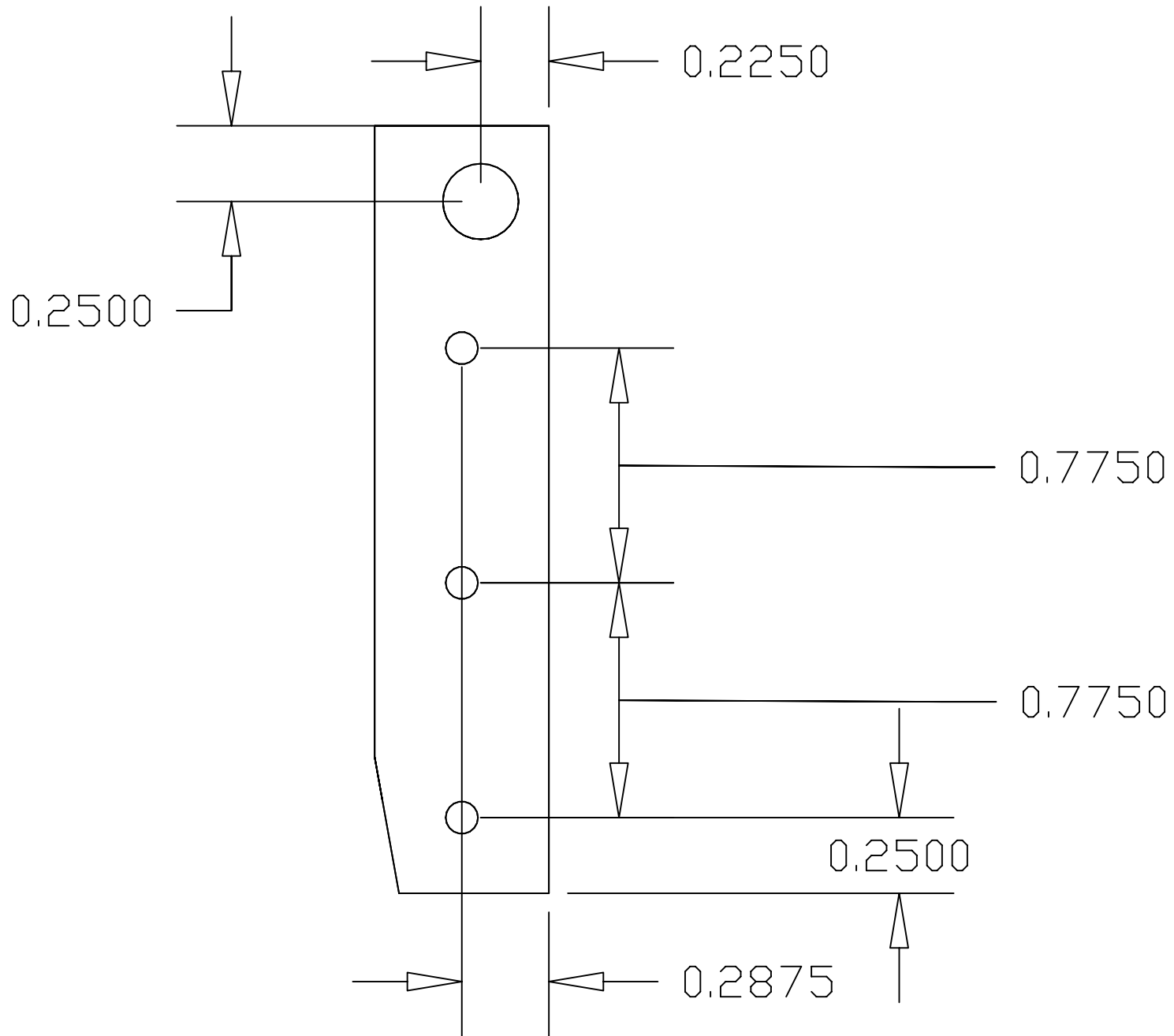

TITLE	AR15 receiver magazine well front	DATE	Nov 2002	REV	A
AUTHOR	Copyright: elmgrove1765@yahoo.com	SHEET	2		

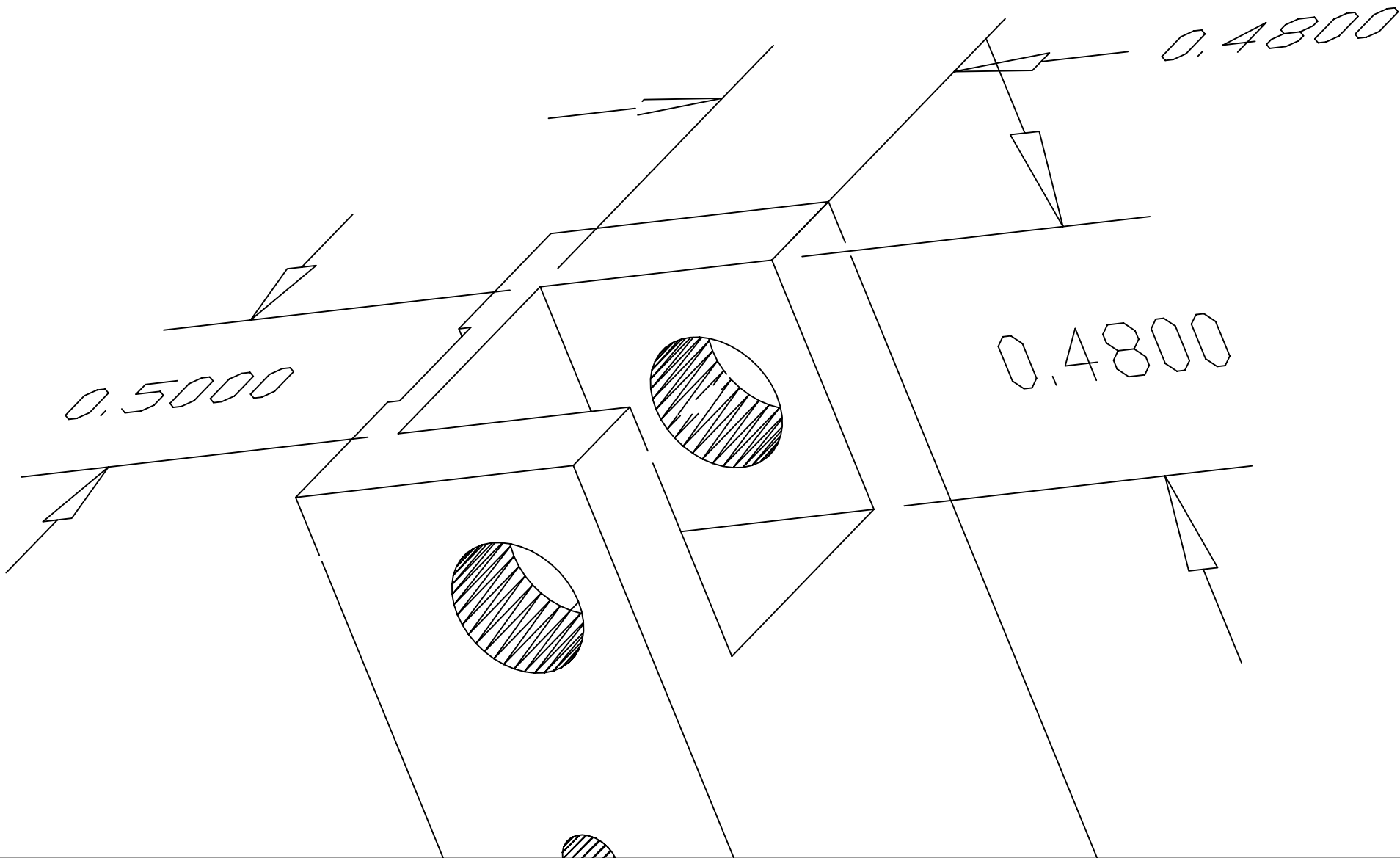

TITLE	AR15 receiver magazine well front	DATE	Nov 2002	REV	A
AUTHOR	Copyright: elmgrove1765@yahoo.com	SHEET	3		

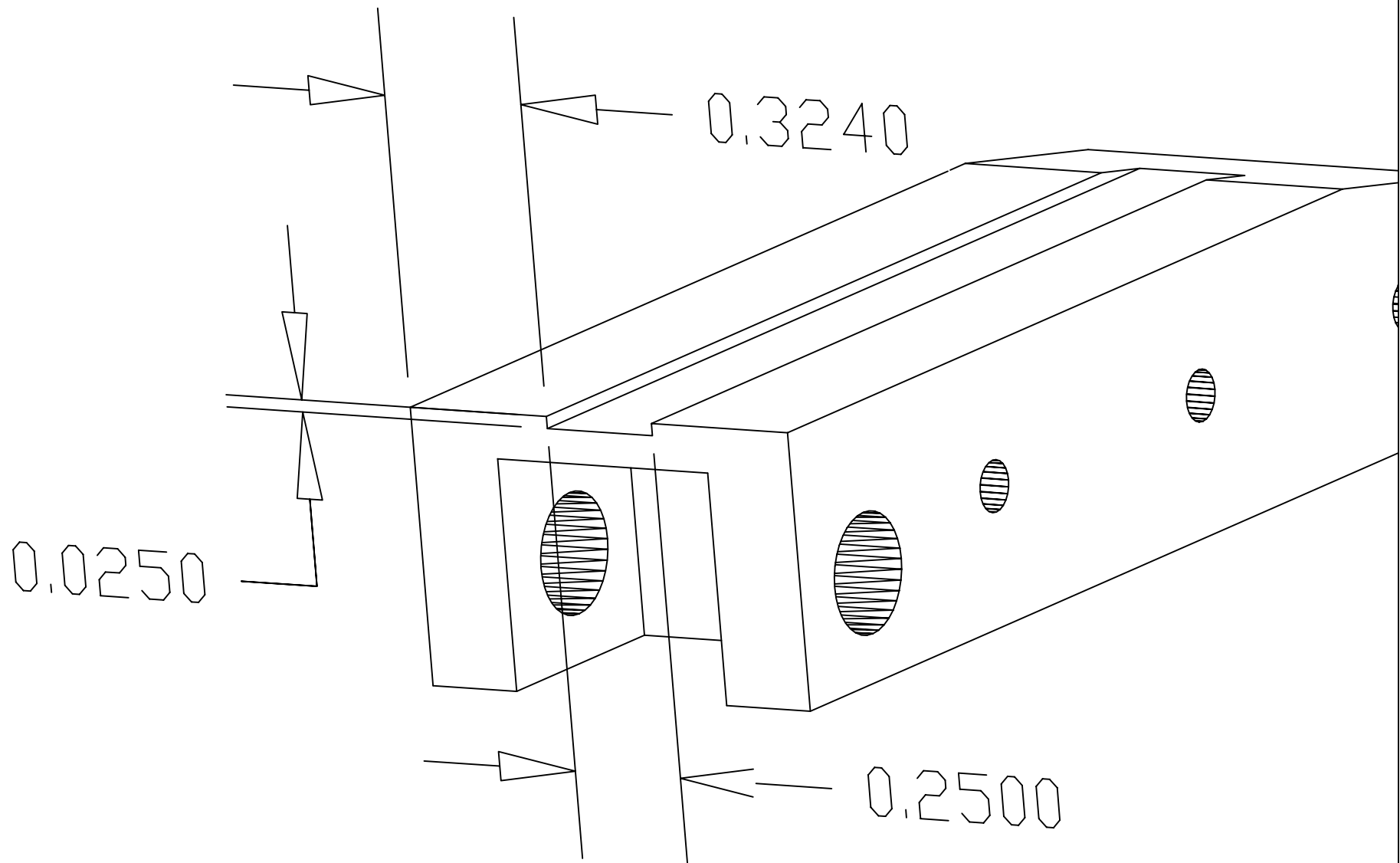

TITLE	AR15 receiver magazine well front	DATE	Nov 2002	REV	A
AUTHOR	Copyright: elmgrove1765@yahoo.com	SHEET	4		

10°

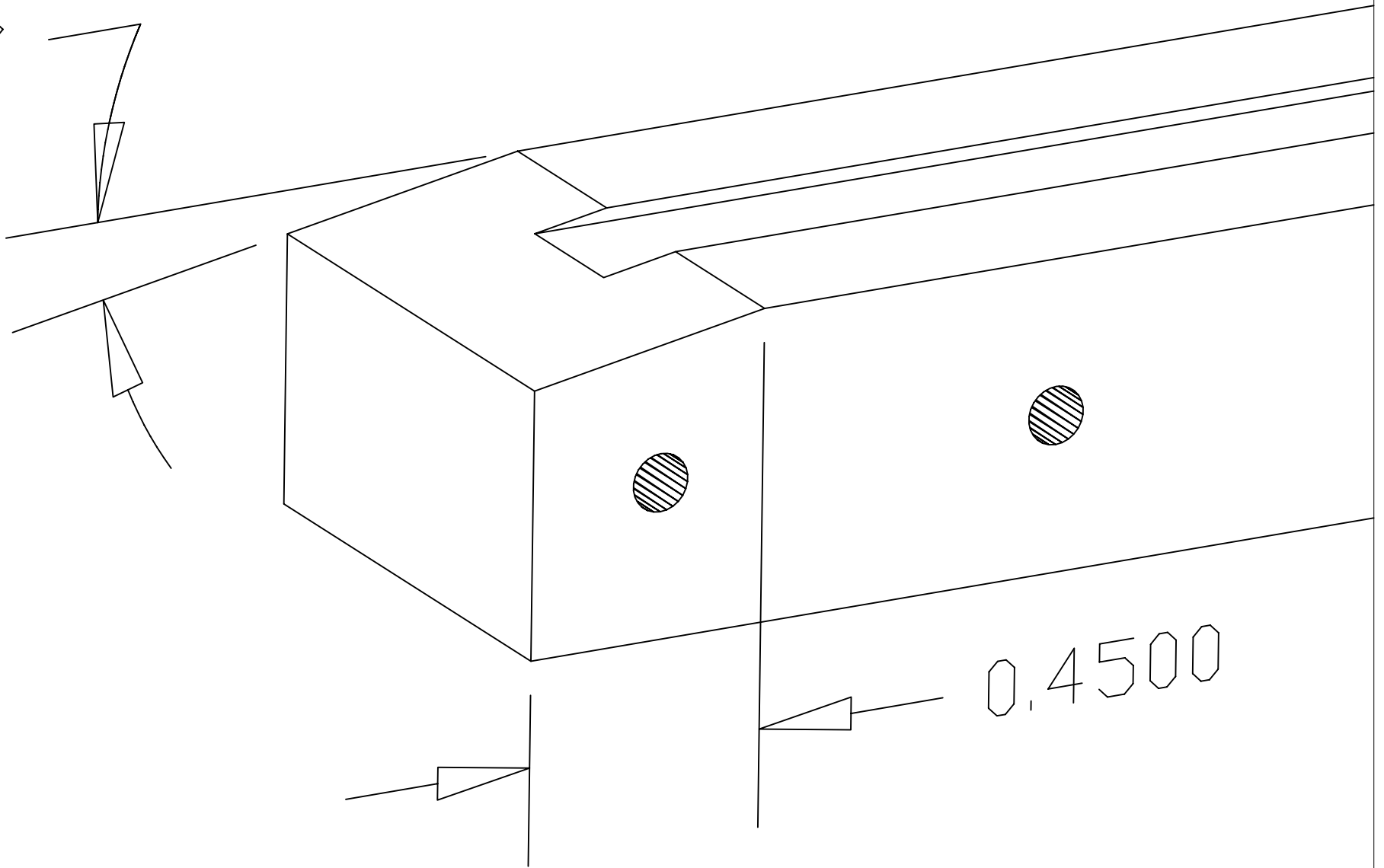

0.4500

TITLE AR15 receiver magazine well front

DATE Nov 2002

REV A

AUTHOR Copyright: elmgrove1765@yahoo.com

SHEET 5

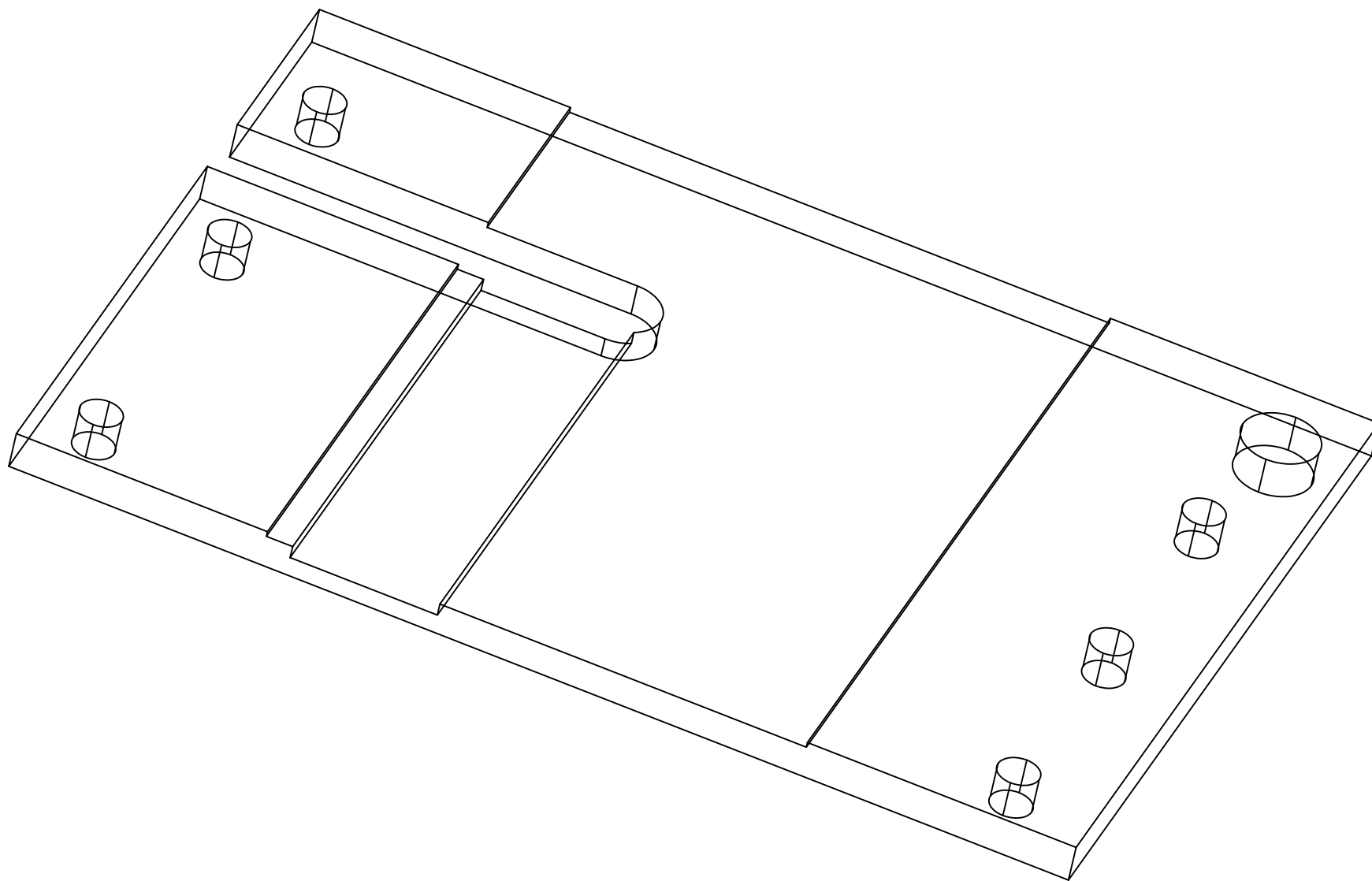

TITLE	AR15 receiver magazine left side	DATE	Mar 2002	REV	A
AUTHOR	Copyright: elmgrove1765@yahoo.com	SHEET	0		

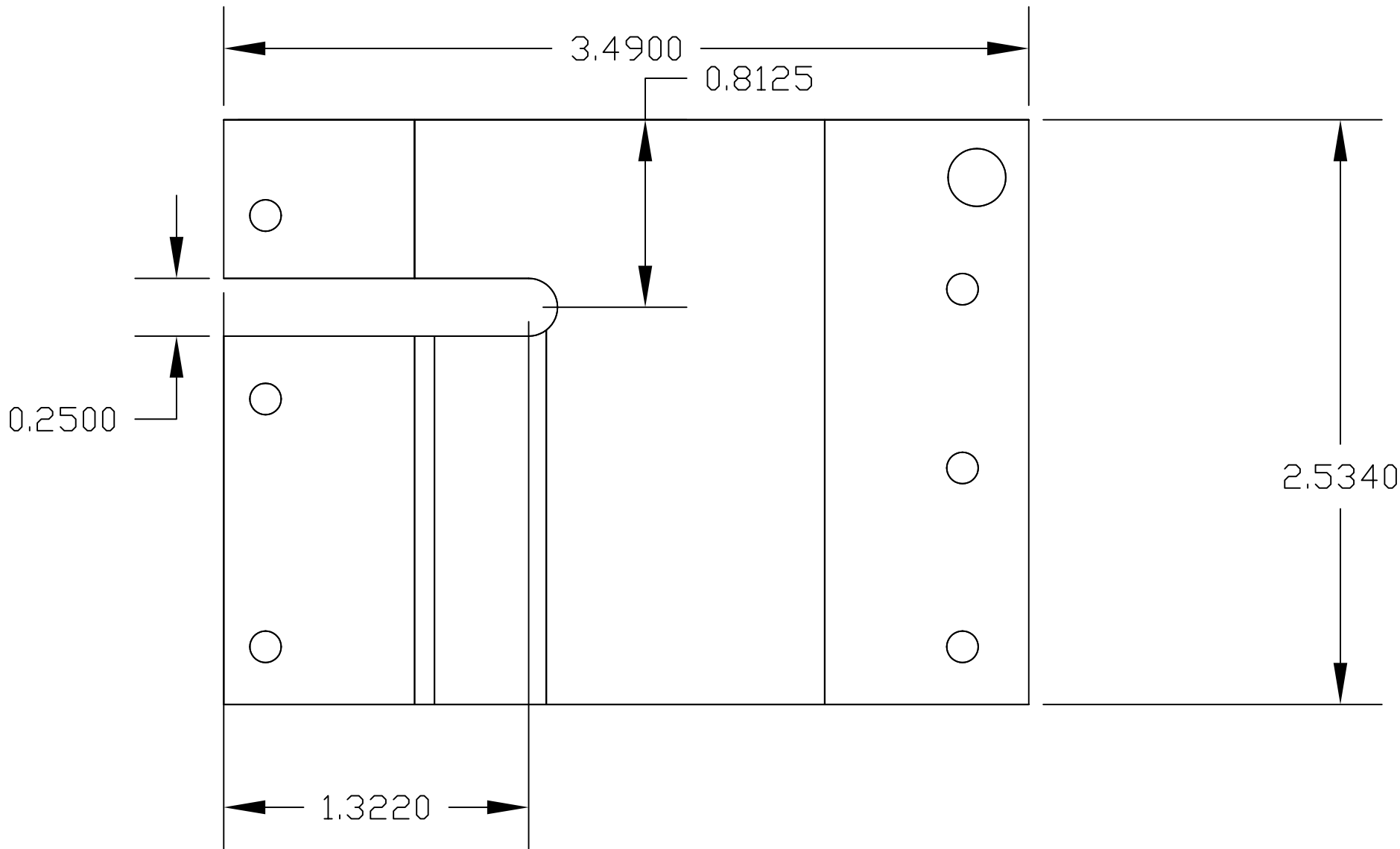

TITLE	AR15 receiver magazine well left side	DATE	Mar 2002	REV	A
AUTHOR	Copyright: elmgrove1765@yahoo.com	SHEET	1		

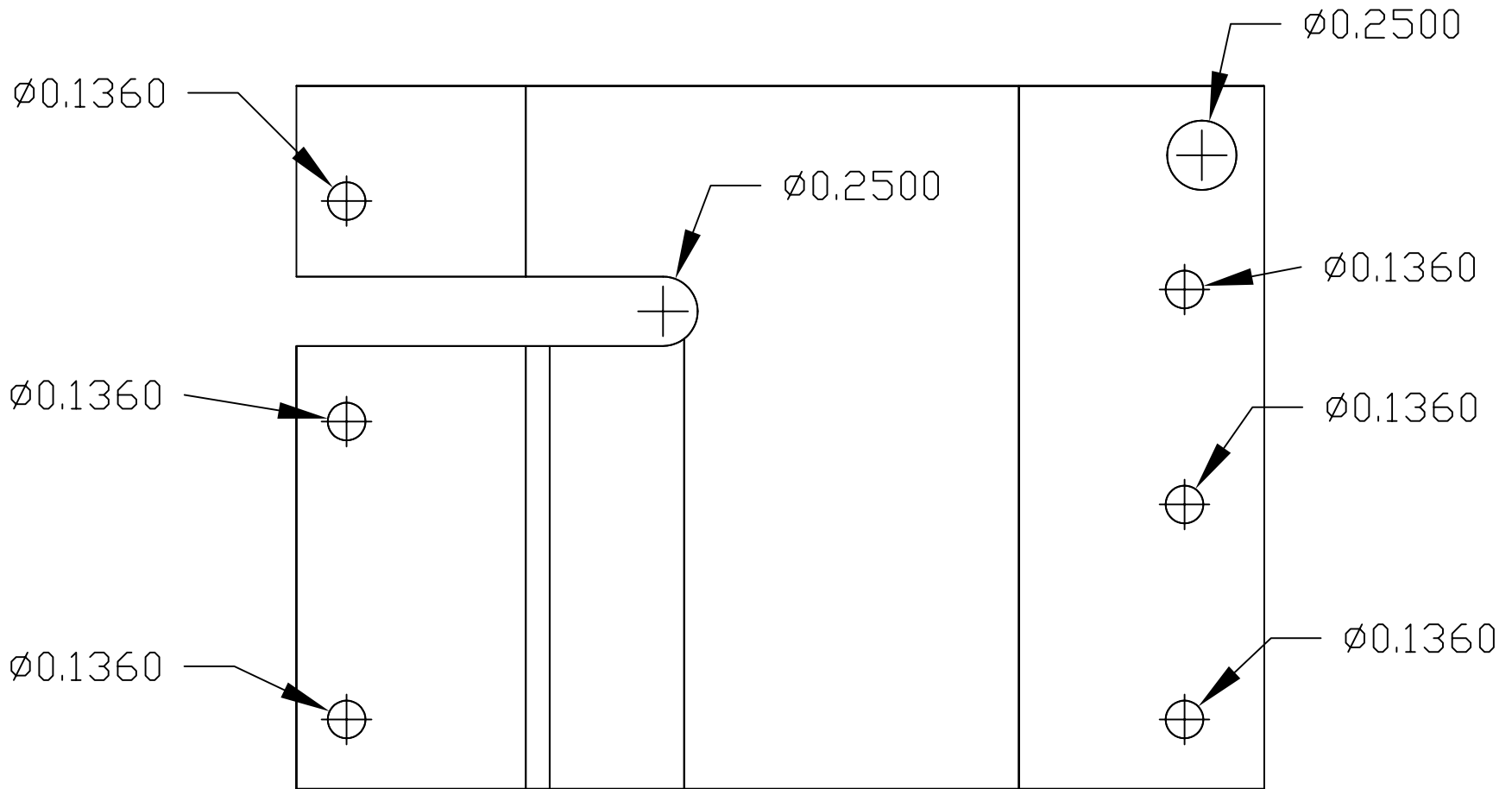

TITLE	AR15 receiver magazine well left side	DATE	Mar 2002	REV	A
AUTHOR	Copyright: elmgrove1765@yahoo.com	SHEET	2		

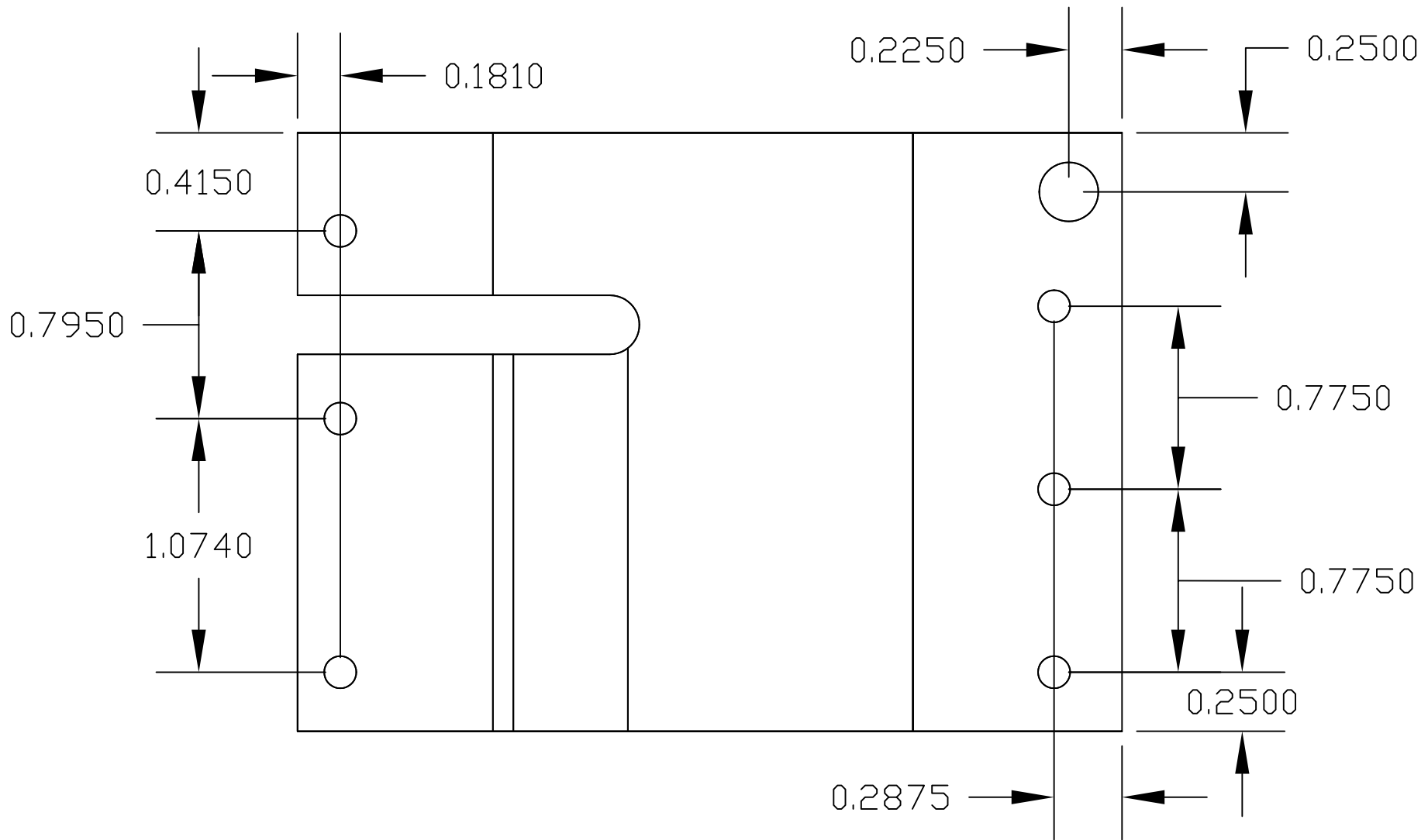

TITLE
AR15 receiver magazine well left side

DATE
Mar 2002

REV
A

AUTHOR
Copyright: elmgrove1765@yahoo.com

SHEET
3

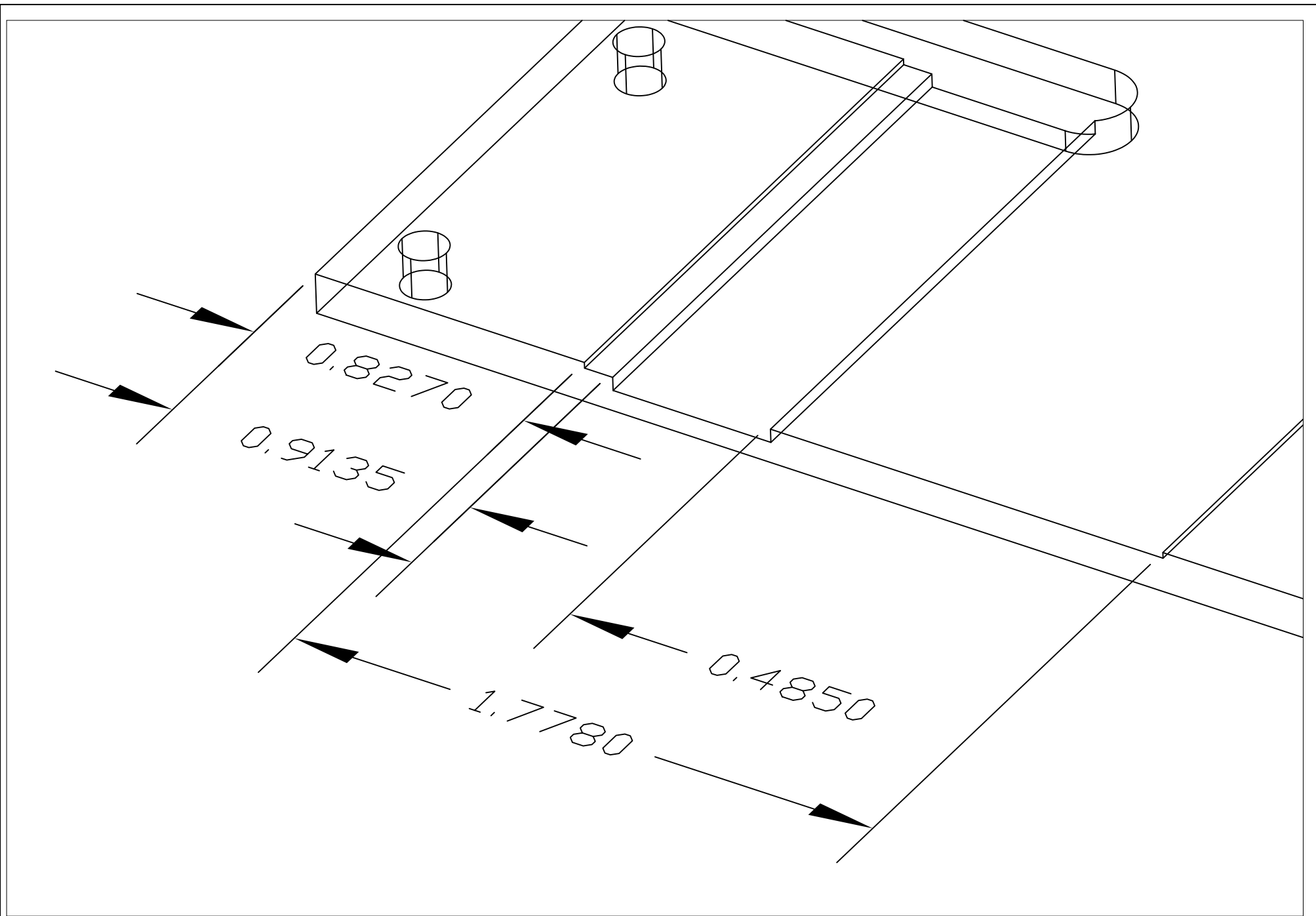

TITLE	AR15 receiver magazine well left side	DATE	Mar 2002	REV	A
AUTHOR	Copyright: elmgrove1765@yahoo.com	SHEET	4		

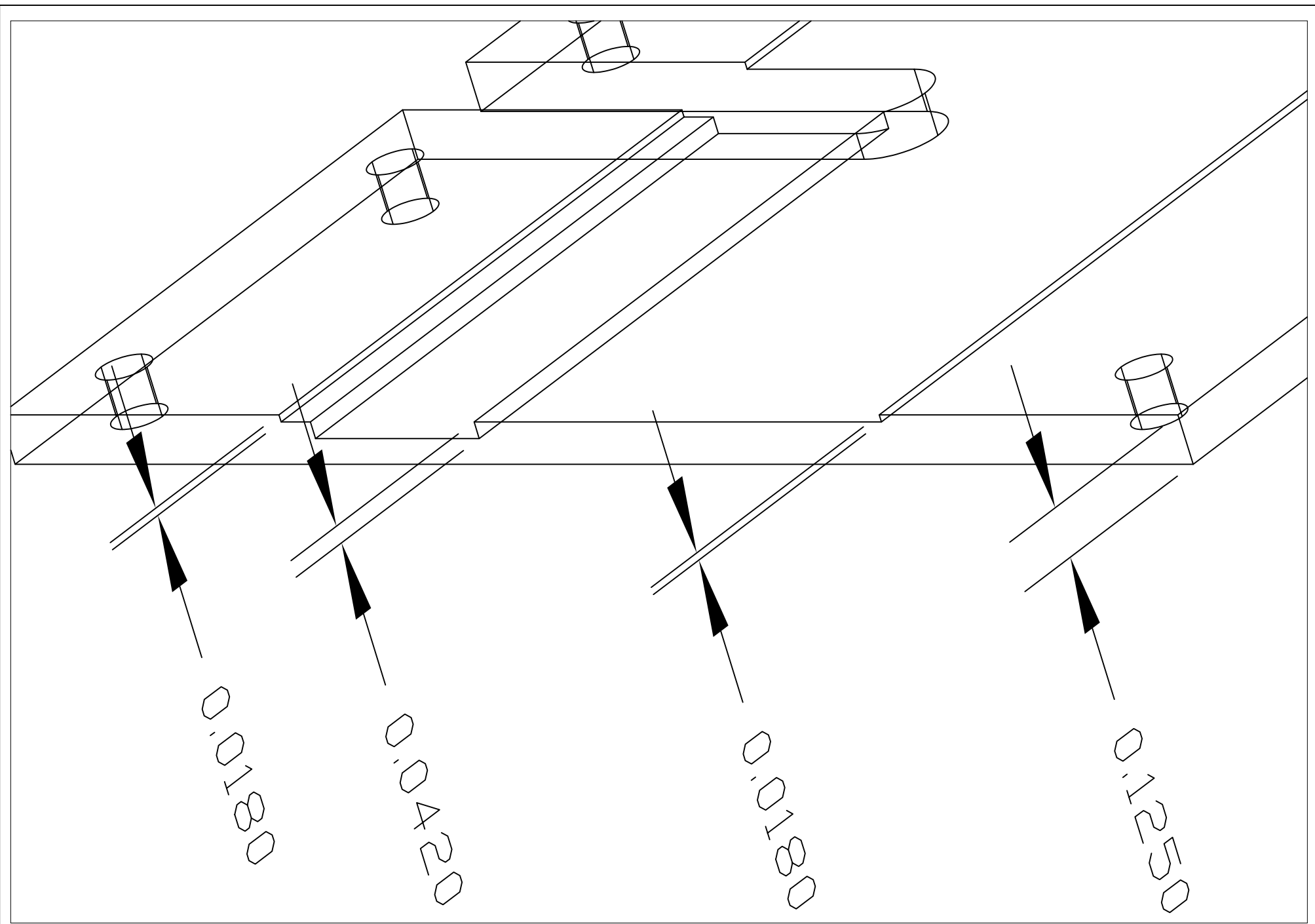

TITLE	AR15 receiver magazine left side	DATE	Mar 2002	REV	A
AUTHOR	Copyright: elmgrove1765@yahoo.com	SHEET	5		

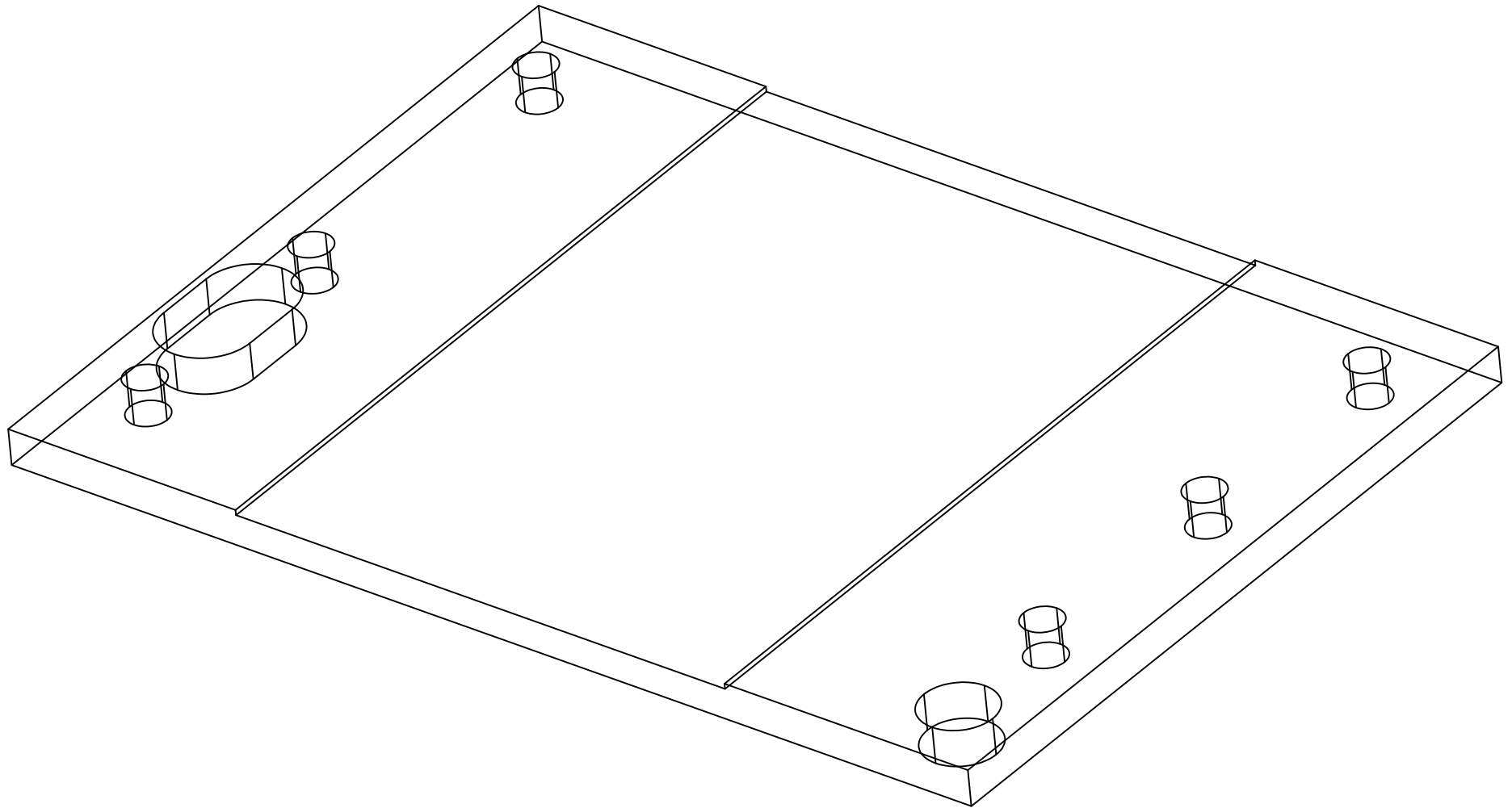

TITLE	AR15 receiver magazine well right side	DATE	Mar 2002	REV	A
AUTHOR	Copyright: elmgrove1765@yahoo.com	SHEET	0		

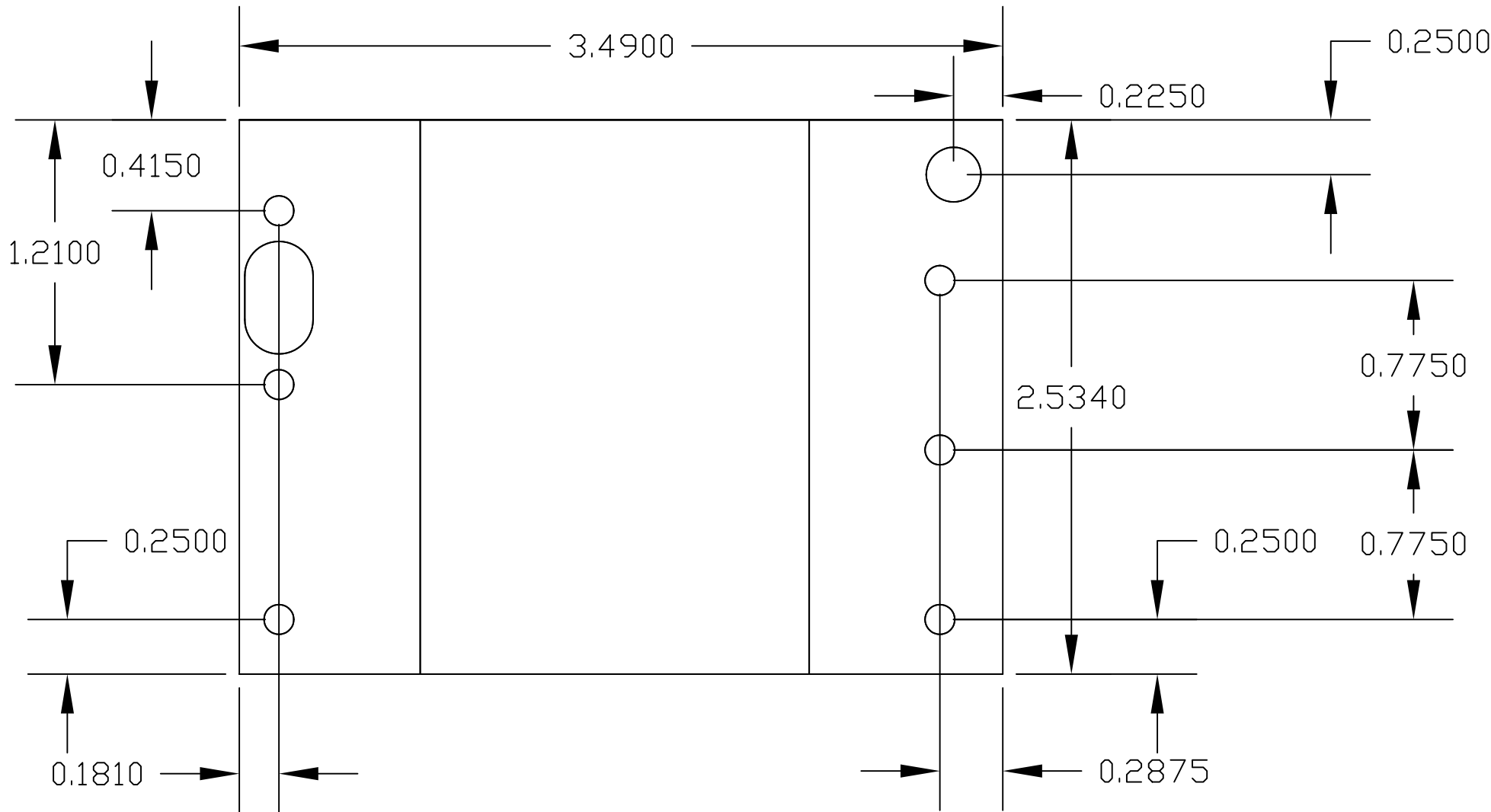

TITLE	AR15 receiver magazine well right side	DATE	Mar 2002	REV	A
AUTHOR	Copyright: elmgrove1765@yahoo.com	SHEET	1		

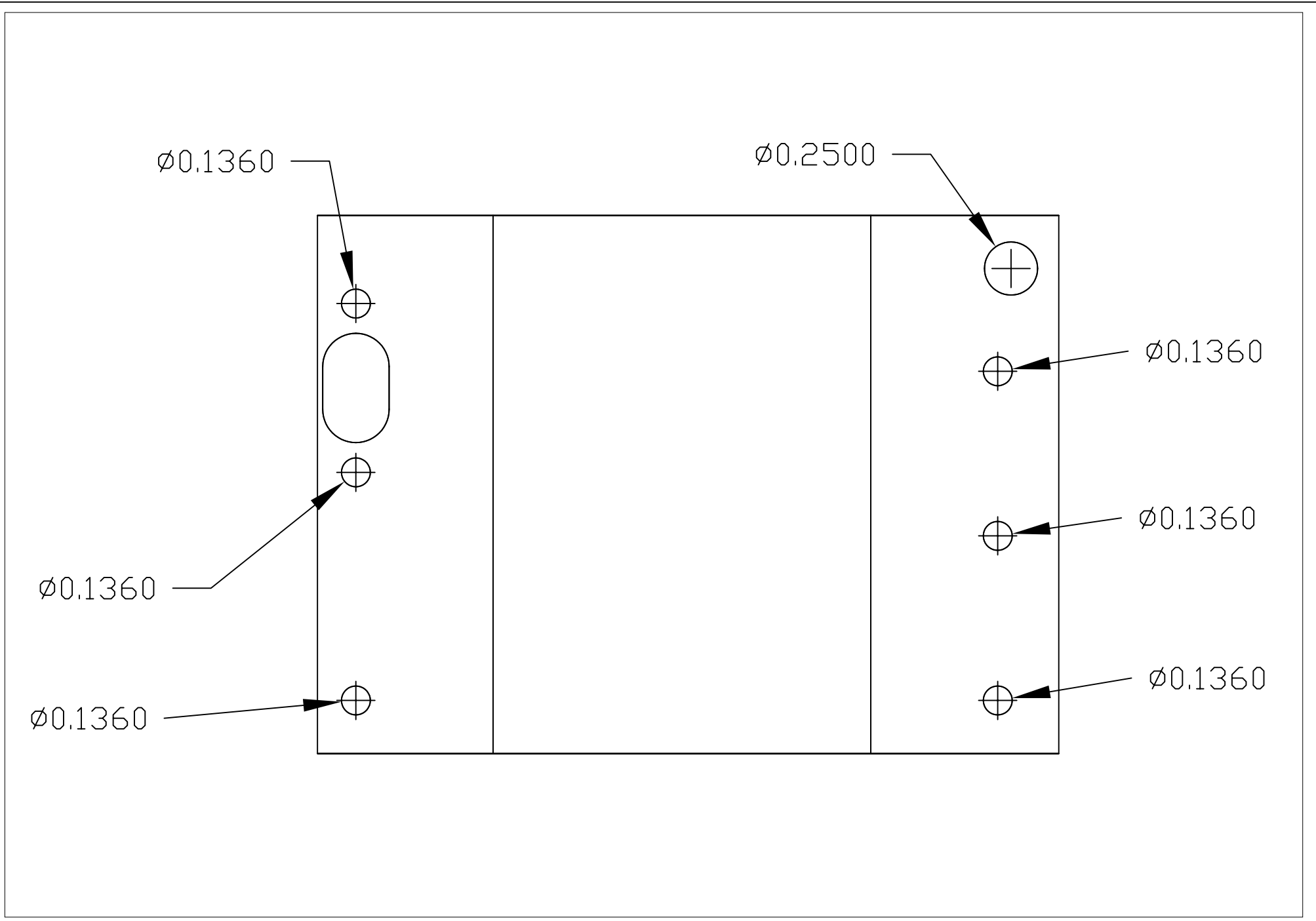

TITLE	AR15 receiver magazine well right side	DATE	Mar 2002	REV	A
AUTHOR	Copyright: elmgrove1765@yahoo.com	SHEET	2		

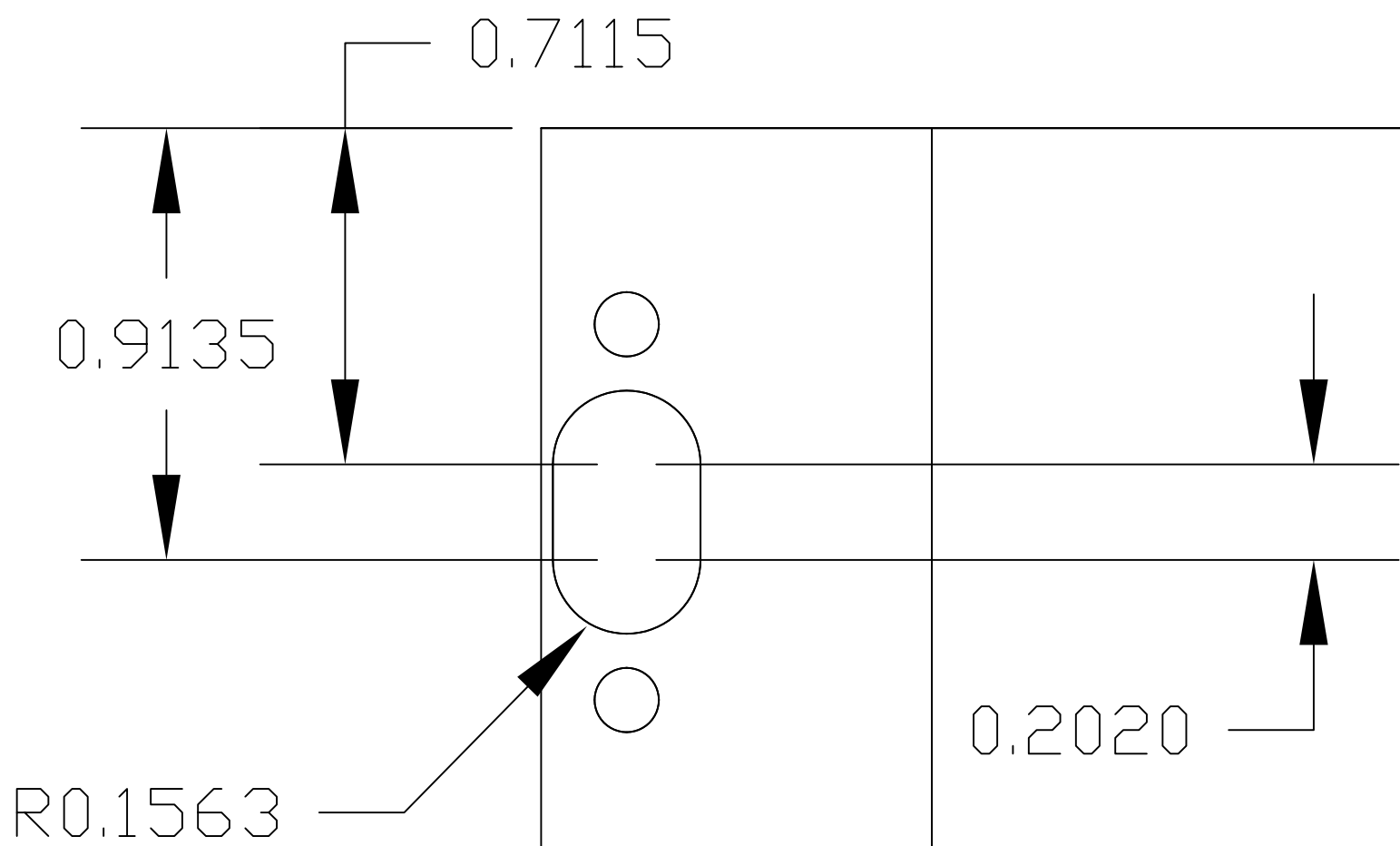

TITLE	AR15 receiver magazine well right side	DATE	Mar 2002	REV	A
AUTHOR	Copyright: elmgrove1765@yahoo.com	SHEET	3		

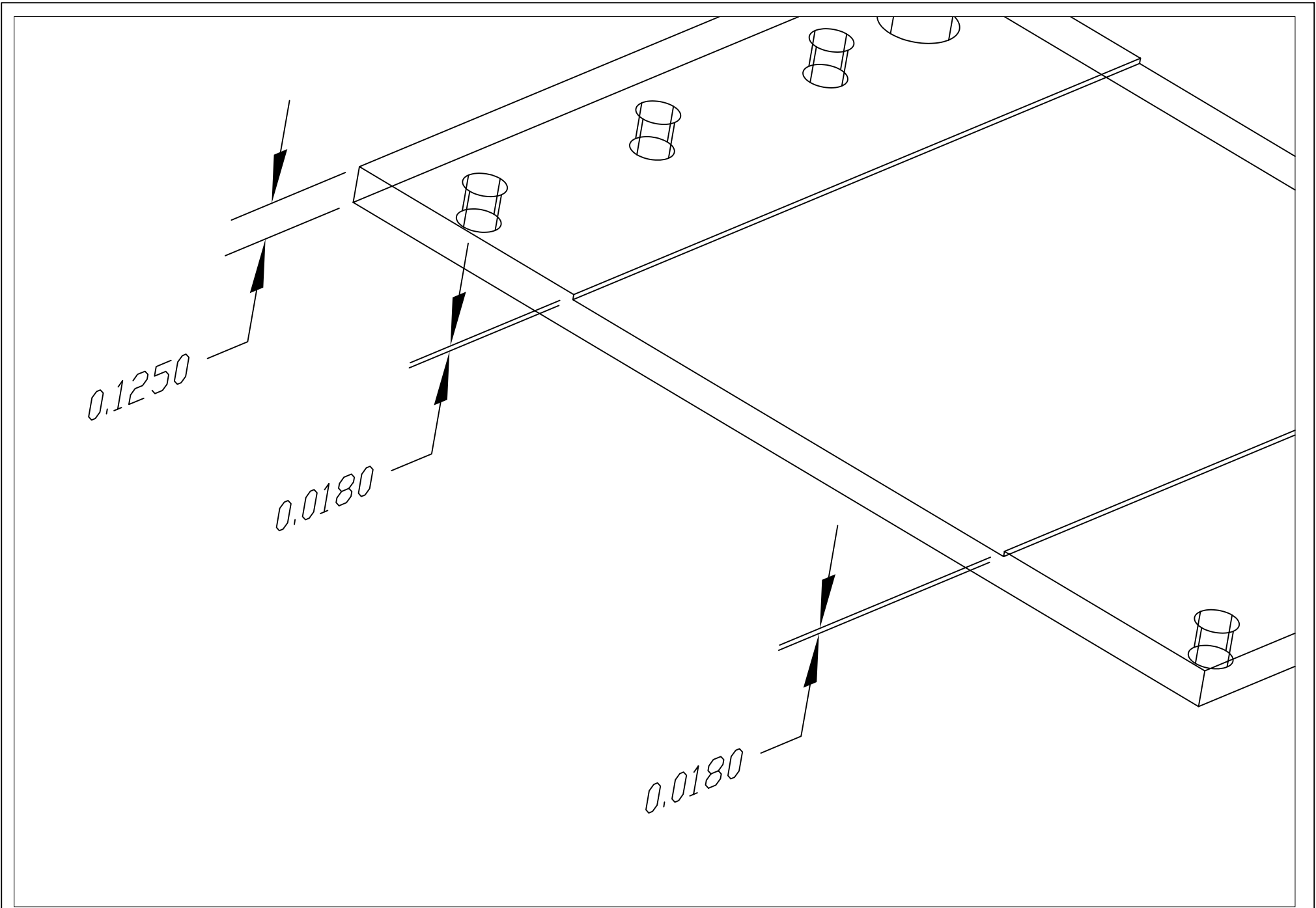

TITLE	AR15 receiver magazine well right side	DATE	Mar 2002	REV	A
AUTHOR	Copyright: elmgrove1765@yahoo.com	SHEET	4		

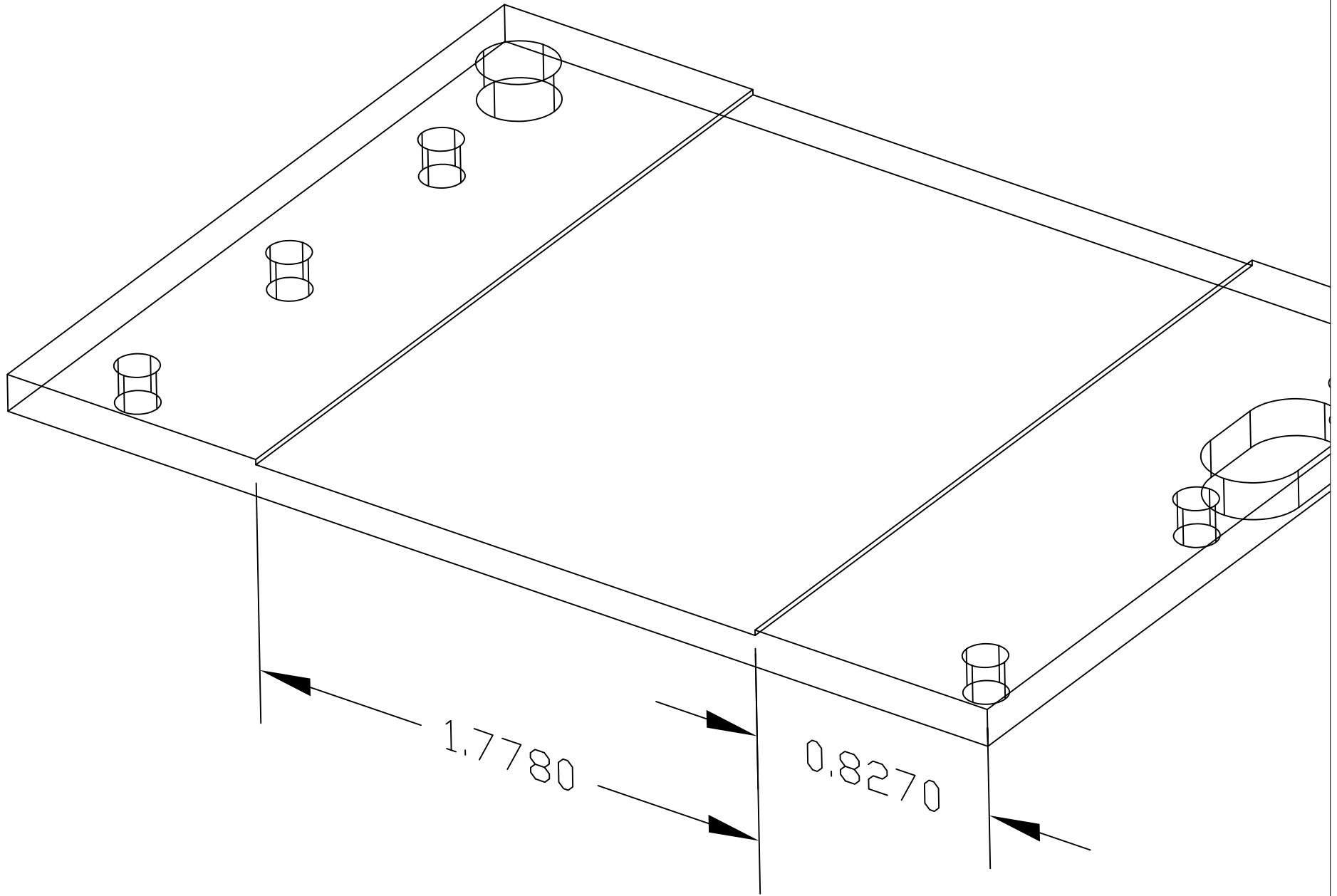

TITLE	AR15 receiver magazine well right side	DATE	Mar 2002	REV	A
AUTHOR	Copyright: elmgrove1765@yahoo.com	SHEET	5		

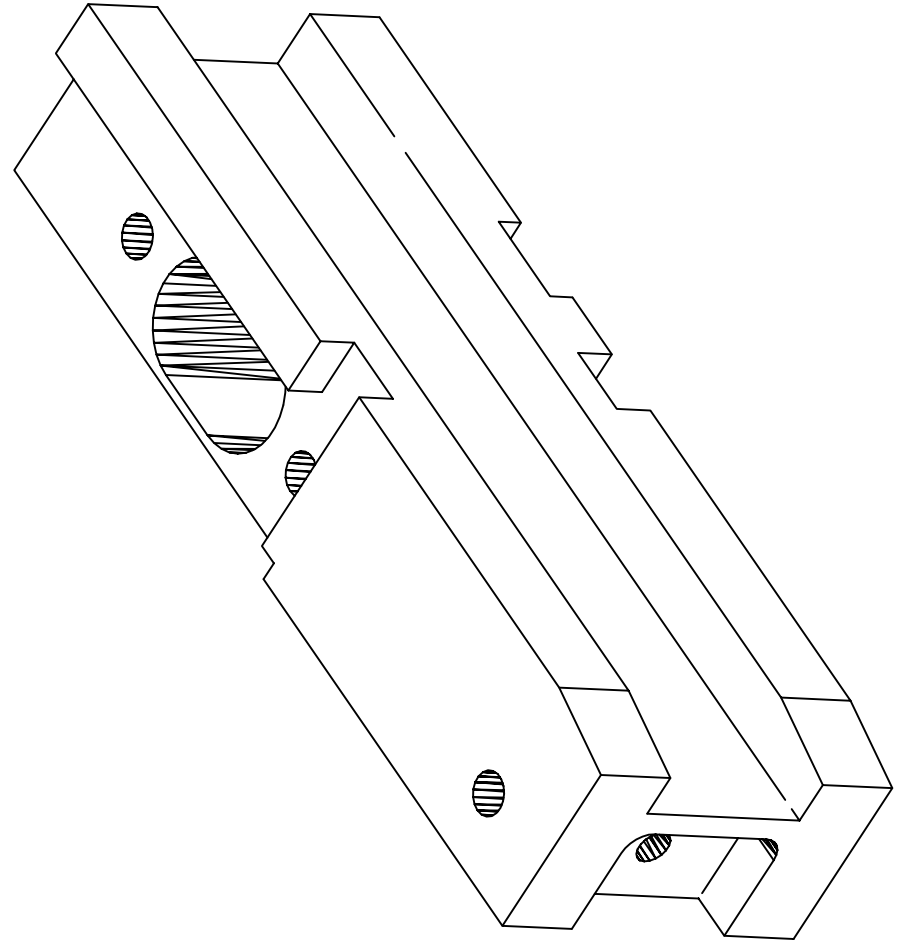
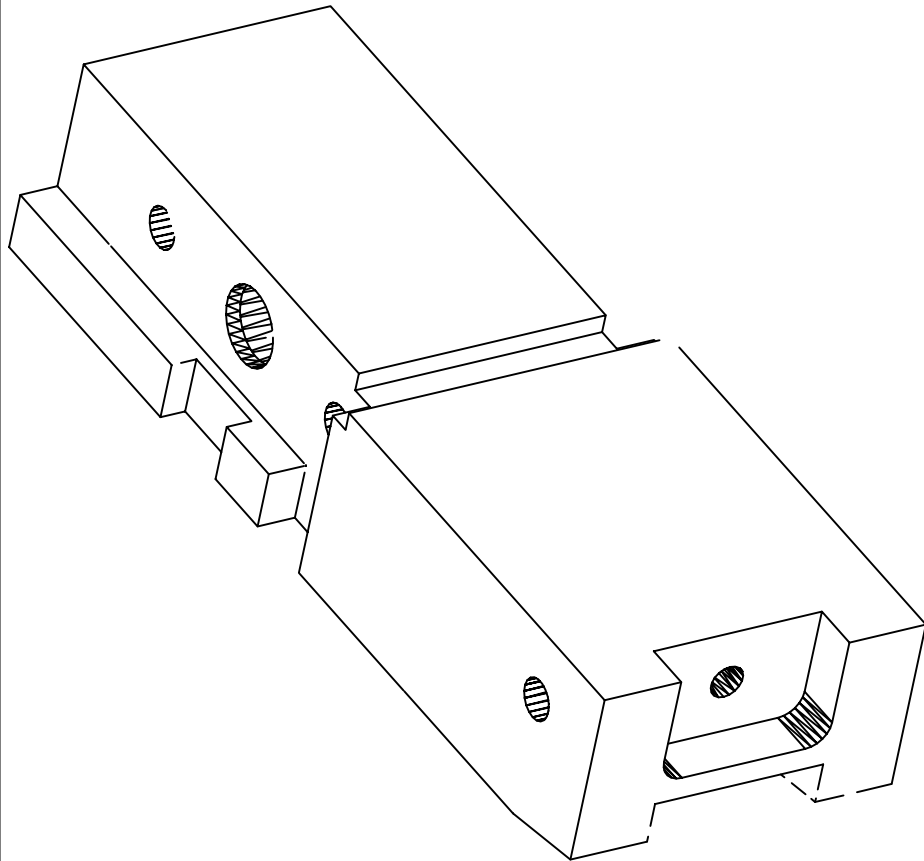

TITLE	AR15 receiver magazine well back	DATE	Feb 2003	REV	A
AUTHOR	Copyright: elmgrove1765@yahoo.com	SHEET	0		

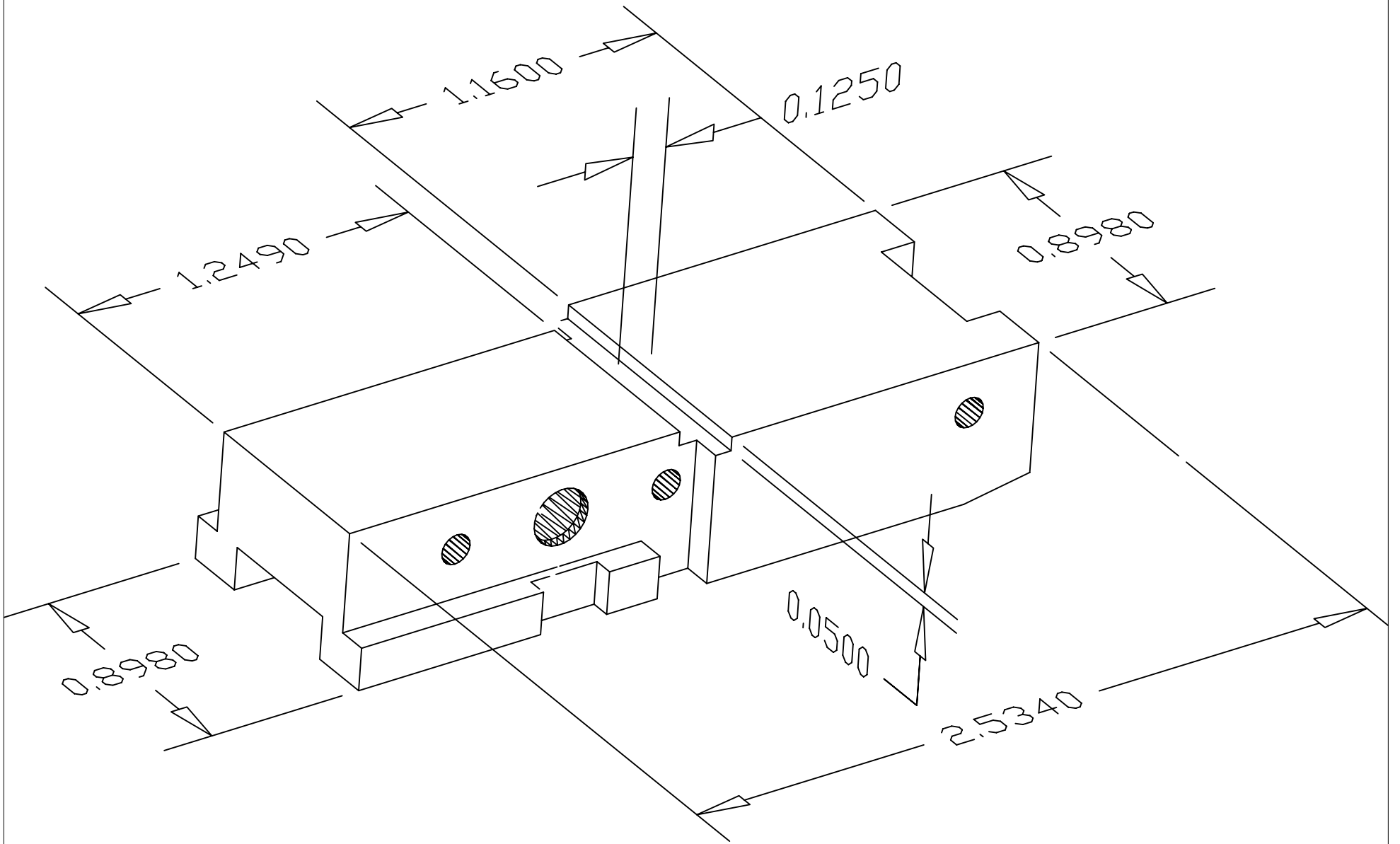

TITLE	AR15 receiver magazine well back	DATE	Feb 2003	REV	A
AUTHOR	Copyright: elmgrove1765@yahoo.com	SHEET	1		

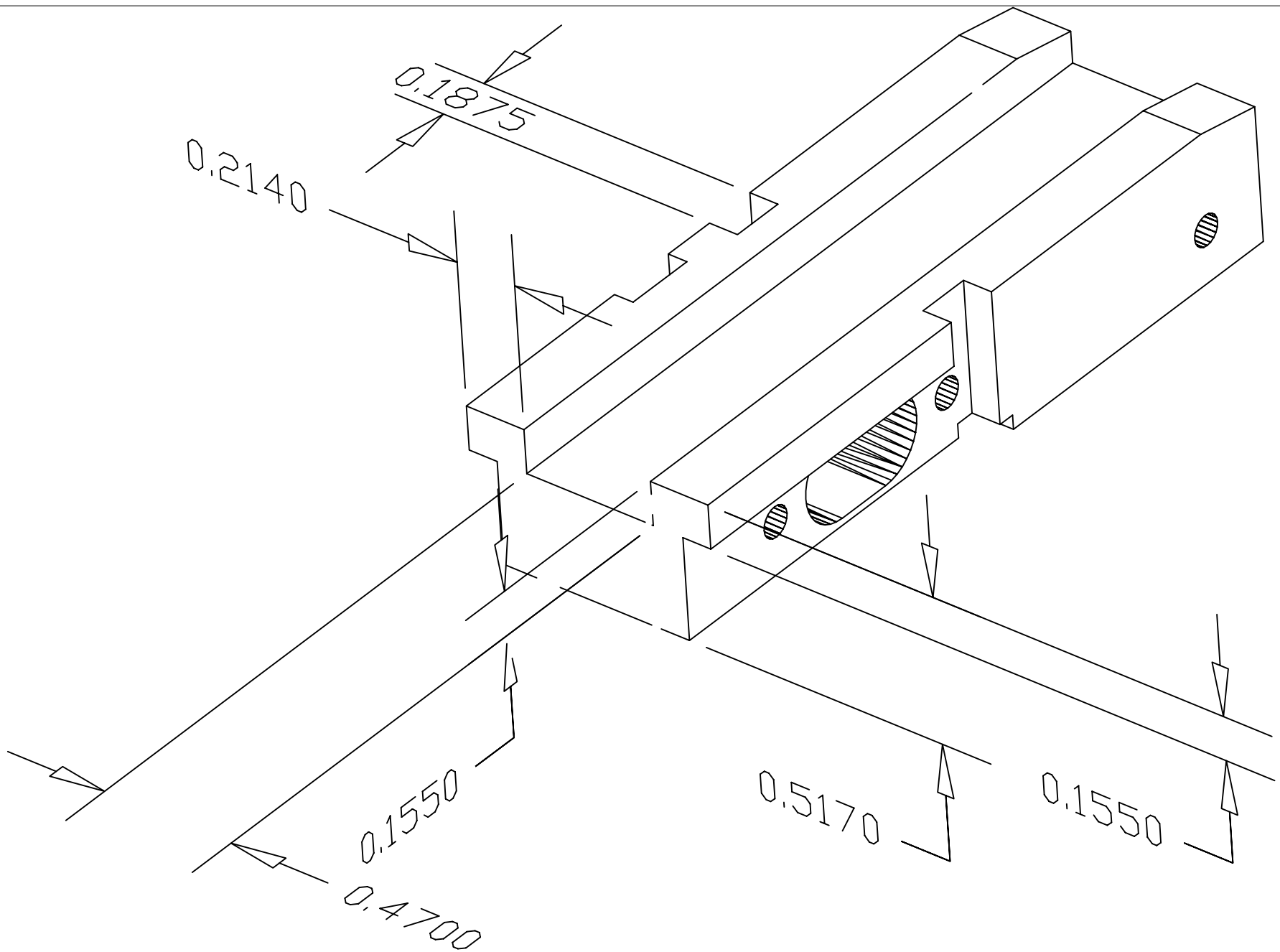

TITLE	AR15 receiver magazine well back	DATE	Feb 2003	REV	A
AUTHOR	Copyright: elmgrove1765@yahoo.com	SHEET	2		

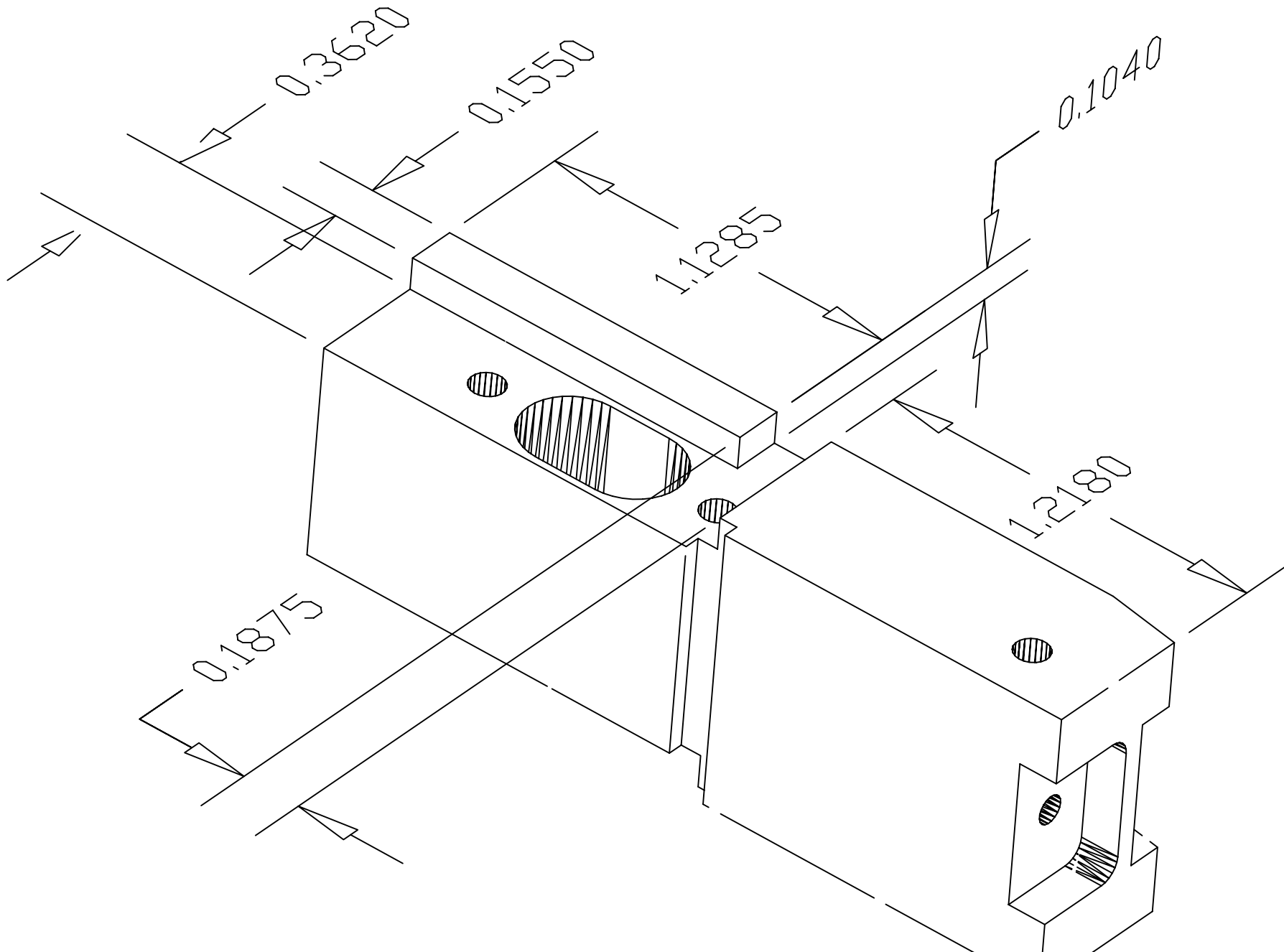

TITLE	AR15 receiver magazine well back	DATE	Feb 2003	REV	A
AUTHOR	Copyright: elmgrove1765@yahoo.com	SHEET	3		

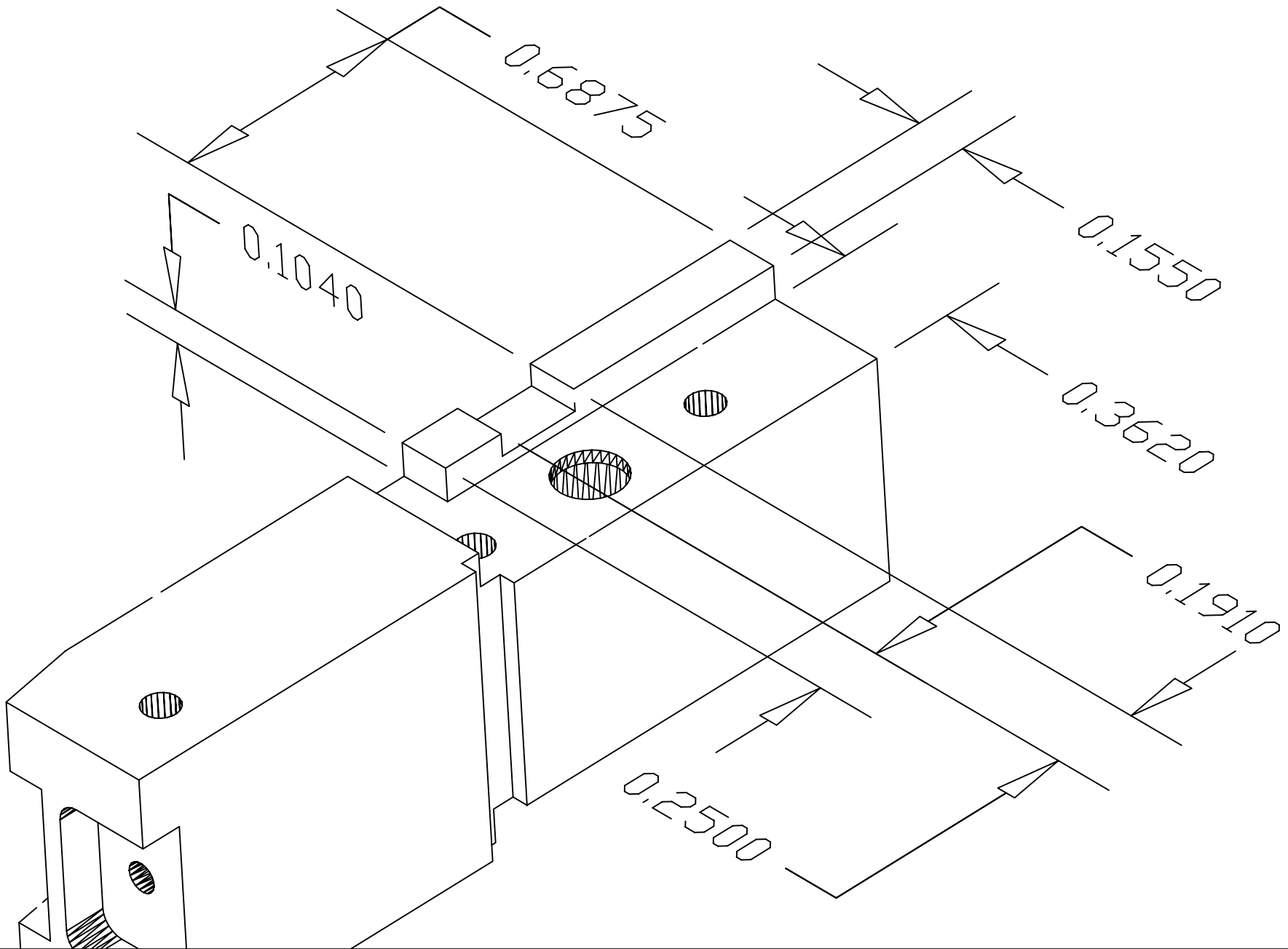

TITLE	AR15 receiver magazine well back	DATE	Feb 2003	REV	A
AUTHOR	Copyright: elmgrove1765@yahoo.com	SHEET	4		

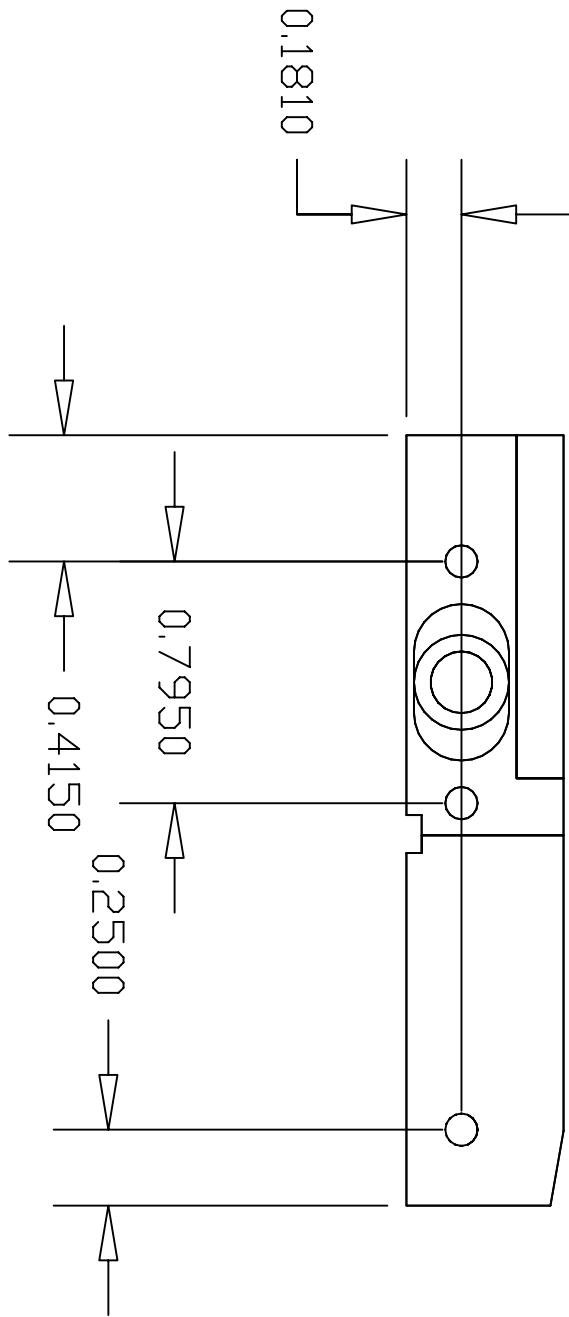

TITLE	AR15 receiver magazine well back	DATE	Feb 2003	REV	A
AUTHOR	Copyright: elmgrove1765@yahoo.com	SHEET	5		

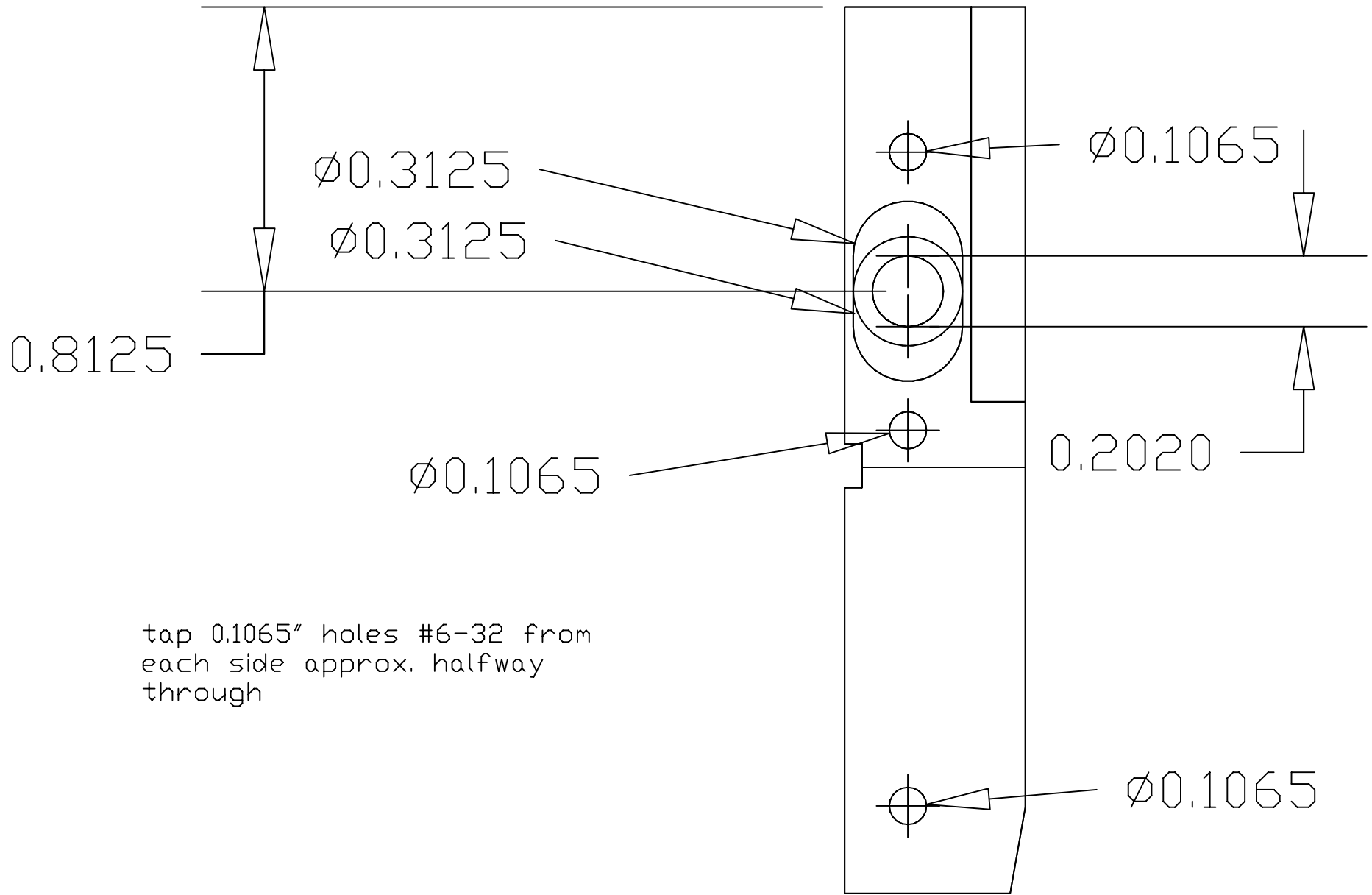

tap 0.1065" holes #6-32 from each side approx. halfway through

TITLE	AR15 receiver magazine well back	DATE	Feb 2003	REV	A
AUTHOR	Copyright: elmgrove1765@yahoo.com	SHEET	6		

Ø0.3125

Ø0.2031

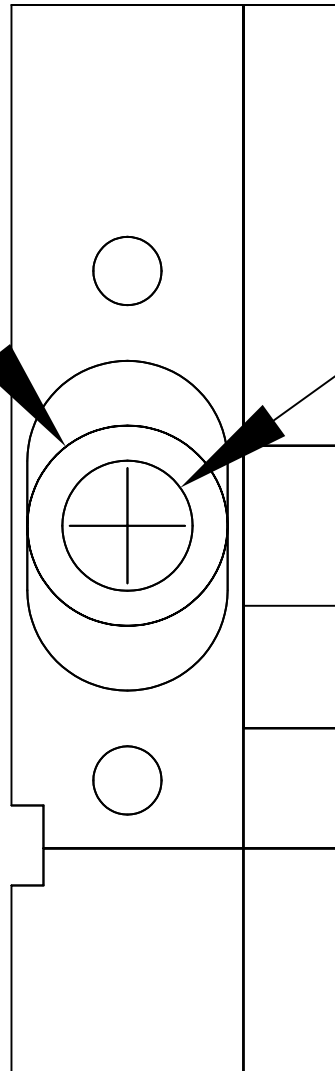

TITLE	AR15 receiver magazine well back	DATE	Feb 2003	REV	A
AUTHOR	Copyright: elmgrove1765@yahoo.com	SHEET	7		

Cross-sectional view

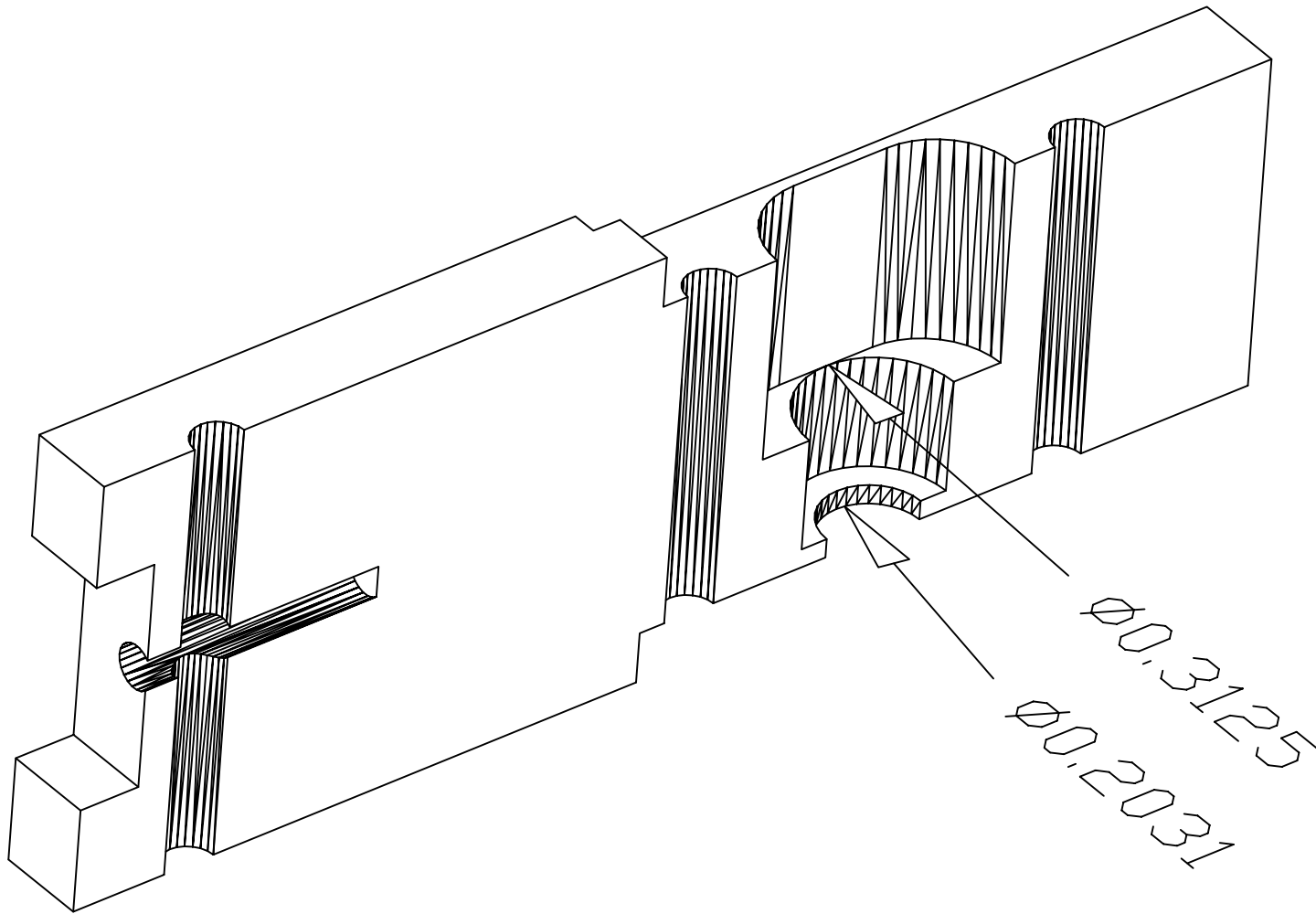

TITLE	AR15 receiver magazine well back
AUTHOR	Copyright: elmgrove1765@yahoo.com

DATE	Feb 2003	REV	A
SHEET	8		

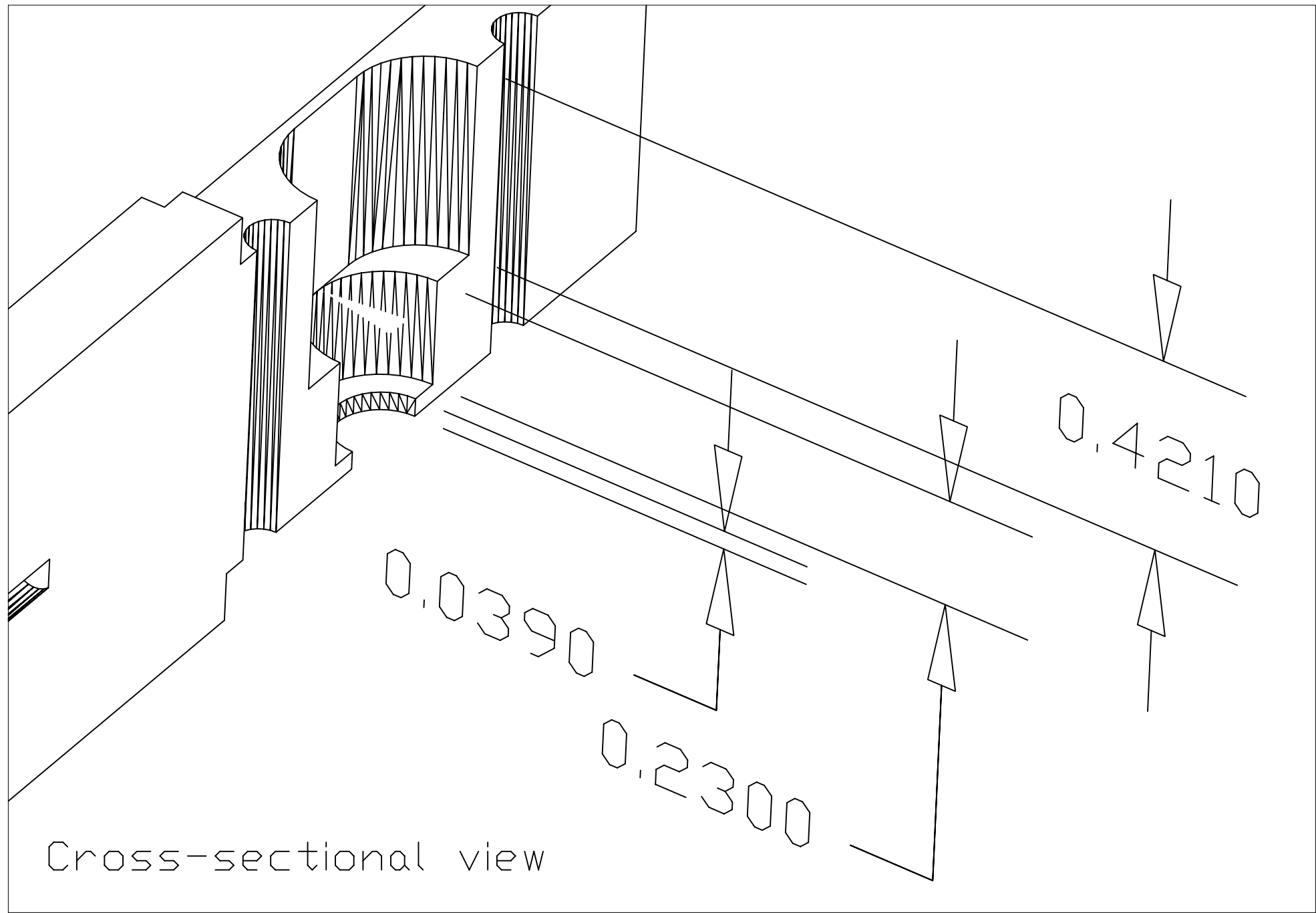

TITLE	AR15 receiver magazine well back	DATE	Feb 2003	REV	A
AUTHOR	Copyright: elmgrove1765@yahoo.com	SHEET	9		

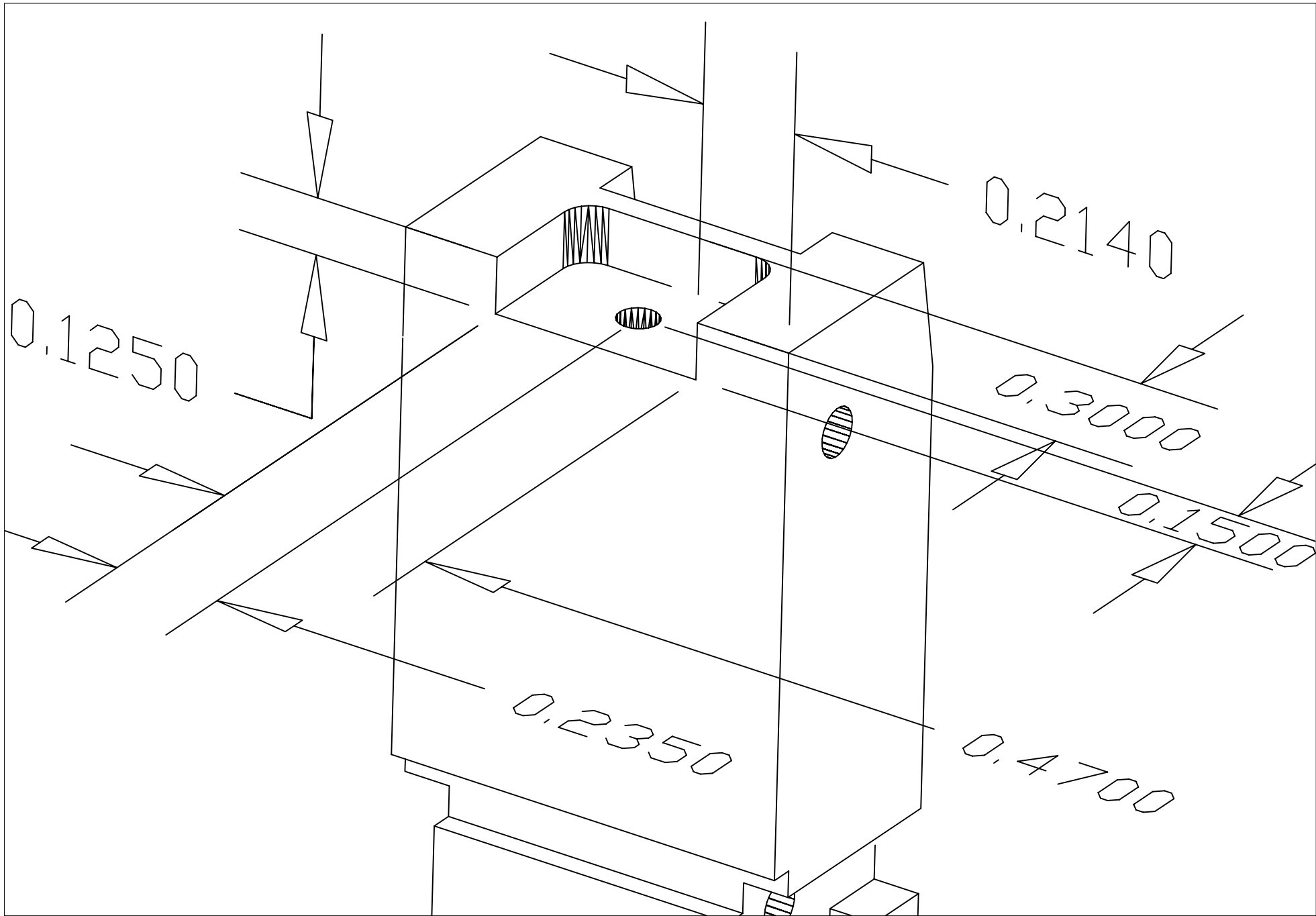

TITLE	AR15 receiver magazine well back	DATE	Feb 2003	REV	A
AUTHOR	Copyright: elmgrove1765@yahoo.com	SHEET	10		

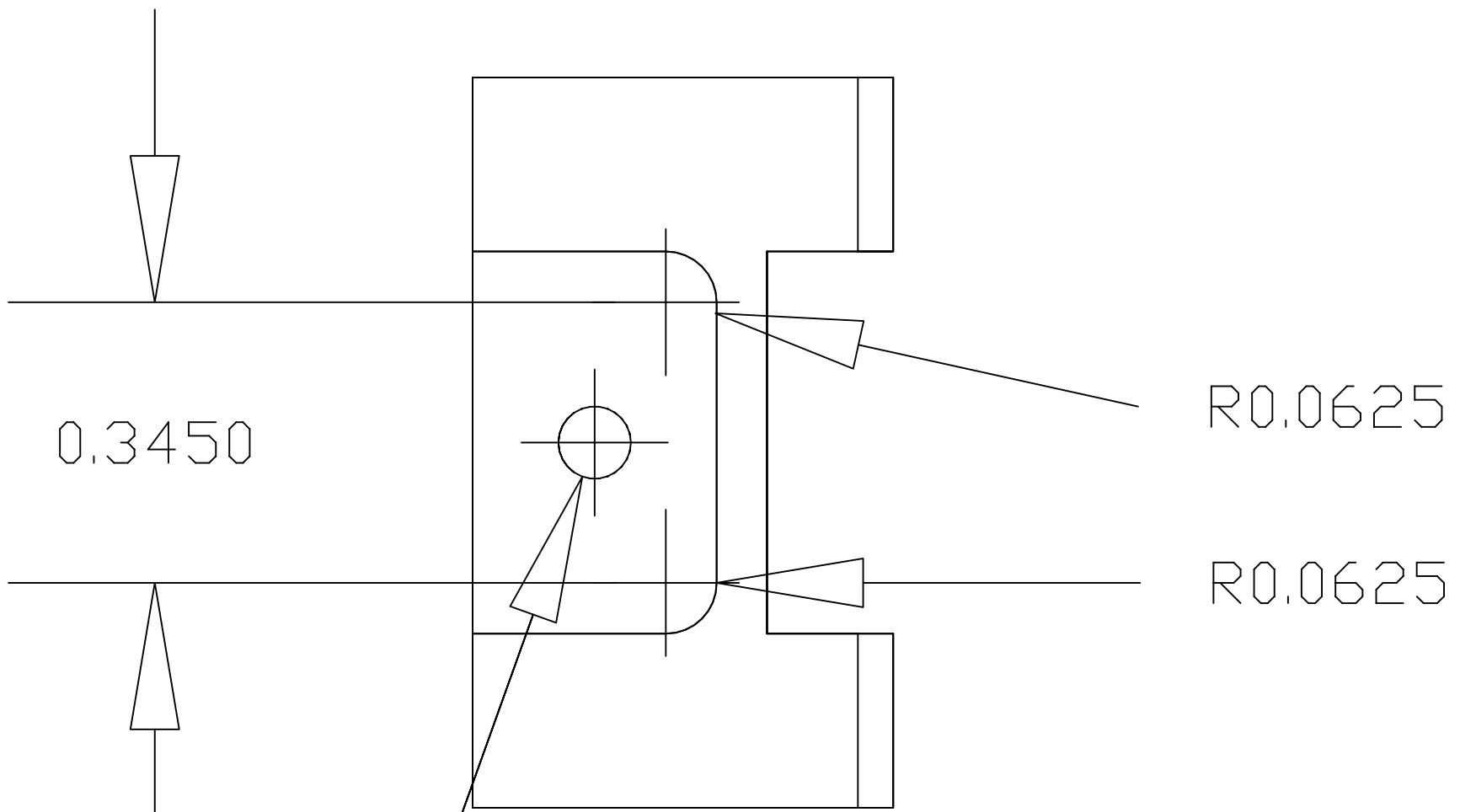

0.3450

R0.0625

R0.0625

∅0.0890

tap .089" hole
 #4-40 to depth of
 approx 0.5"

TITLE	AR15 receiver magazine well back	DATE	Feb 2003	REV	A
AUTHOR	Copyright: elmgrove1765@yahoo.com	SHEET	11		

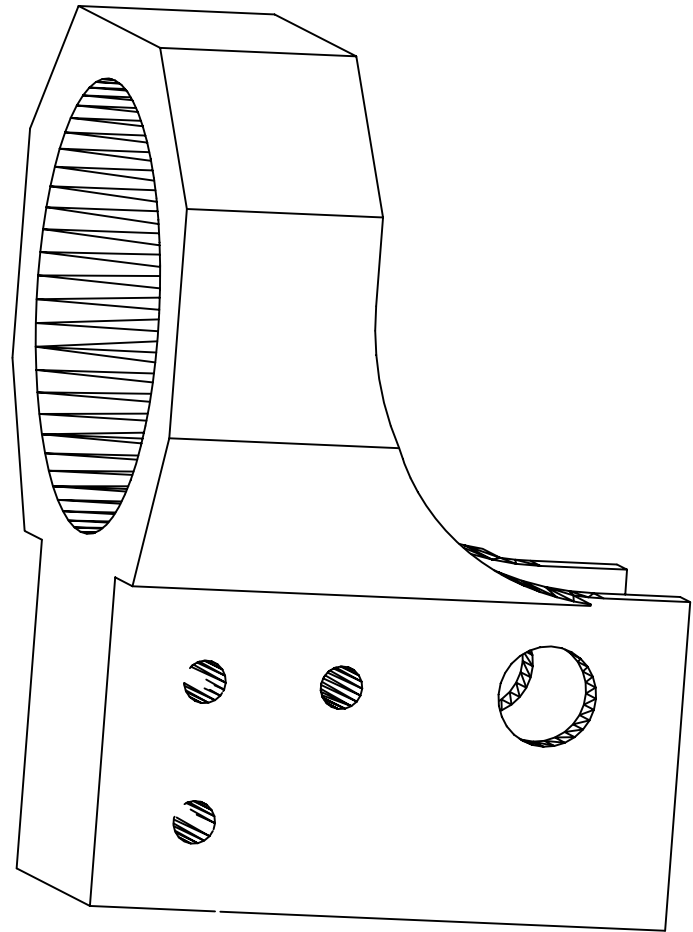
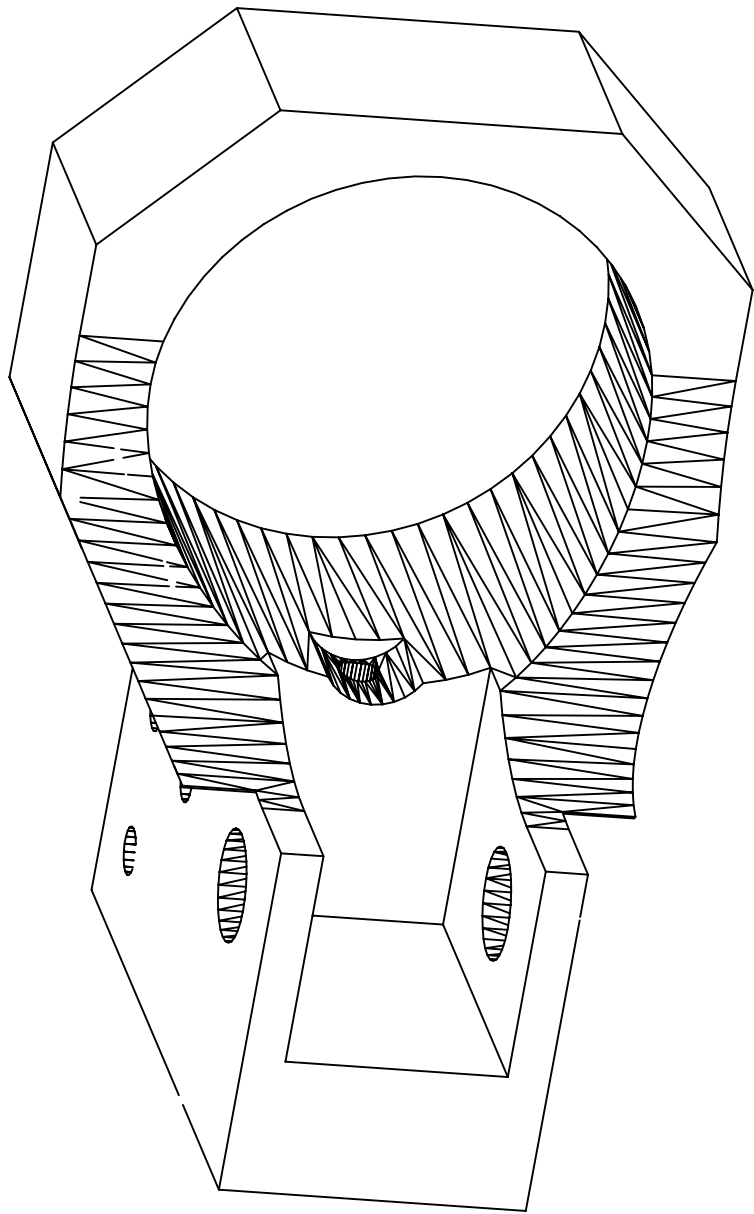

TITLE	AR15 receiver buffer	DATE	Dec 2002	REV	A
AUTHOR	Copyright: elmgrove1765@yahoo.com	SHEET	0		

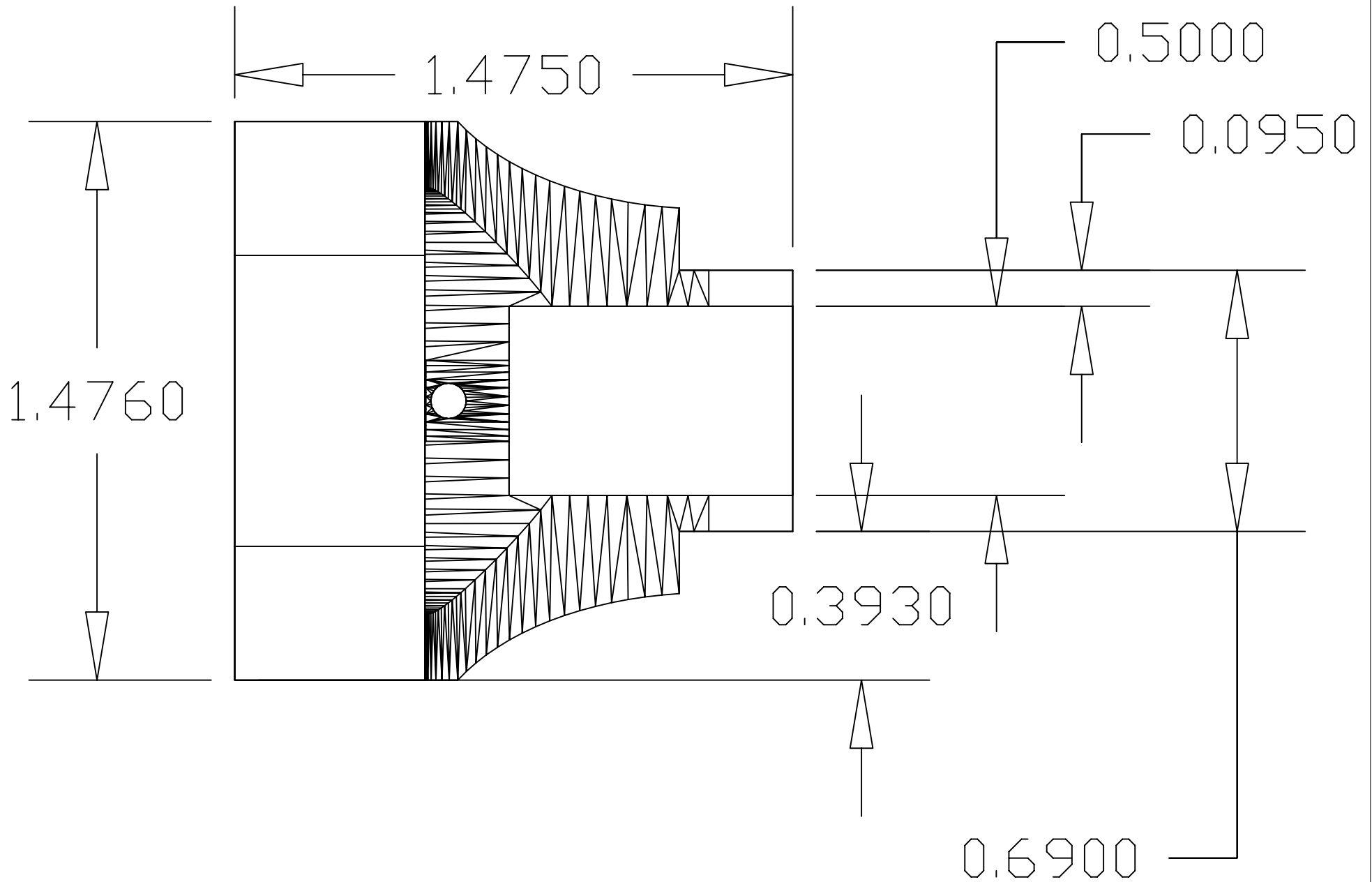

TITLE	AR15 receiver buffer	DATE	Dec 2002	REV	A
AUTHOR	Copyright: elmgrove1765@yahoo.com	SHEET	1		

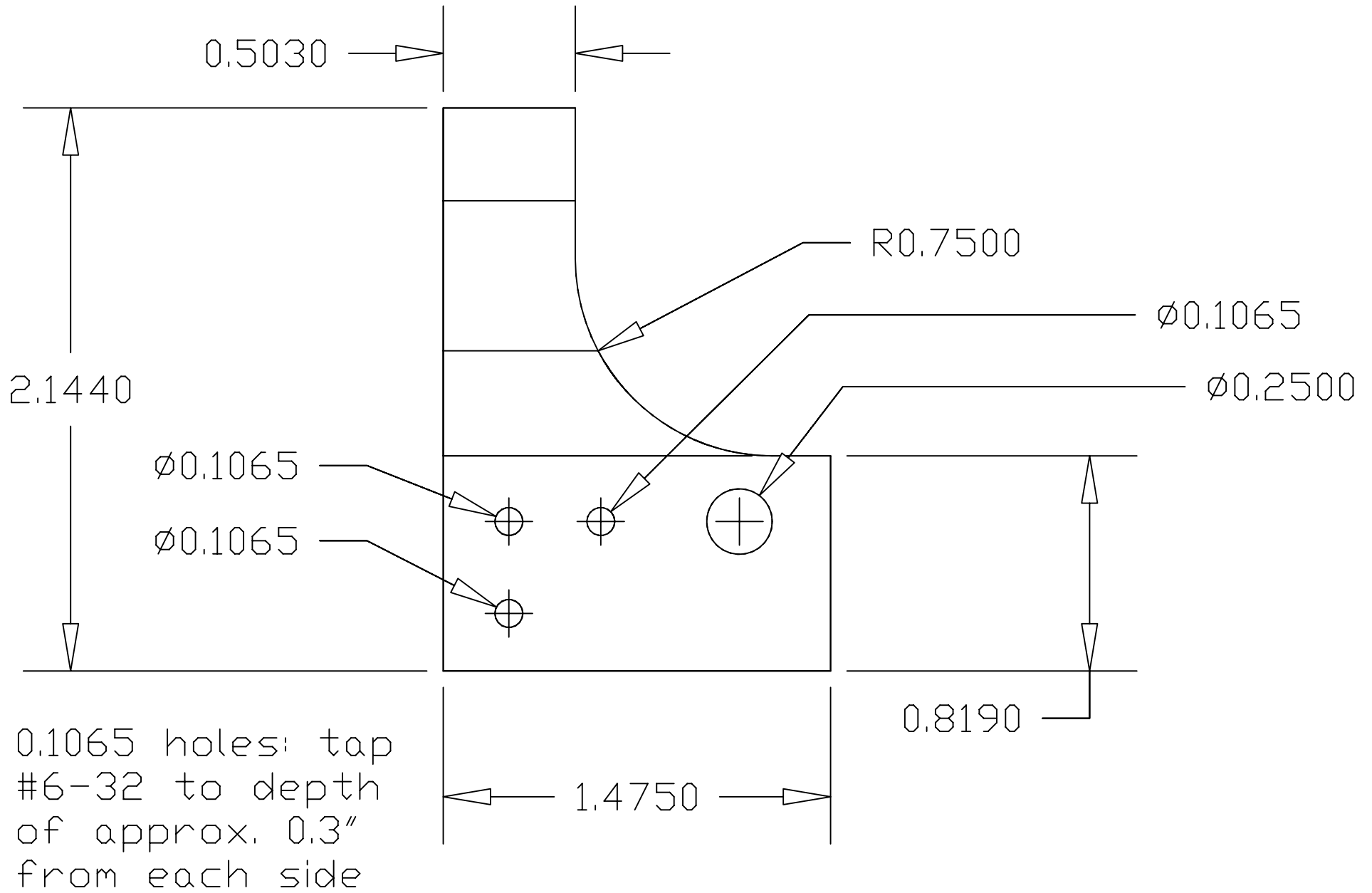

TITLE	AR15 receiver buffer	DATE	Dec 2002	REV	A
AUTHOR	Copyright: elmgrove1765@yahoo.com	SHEET	2		

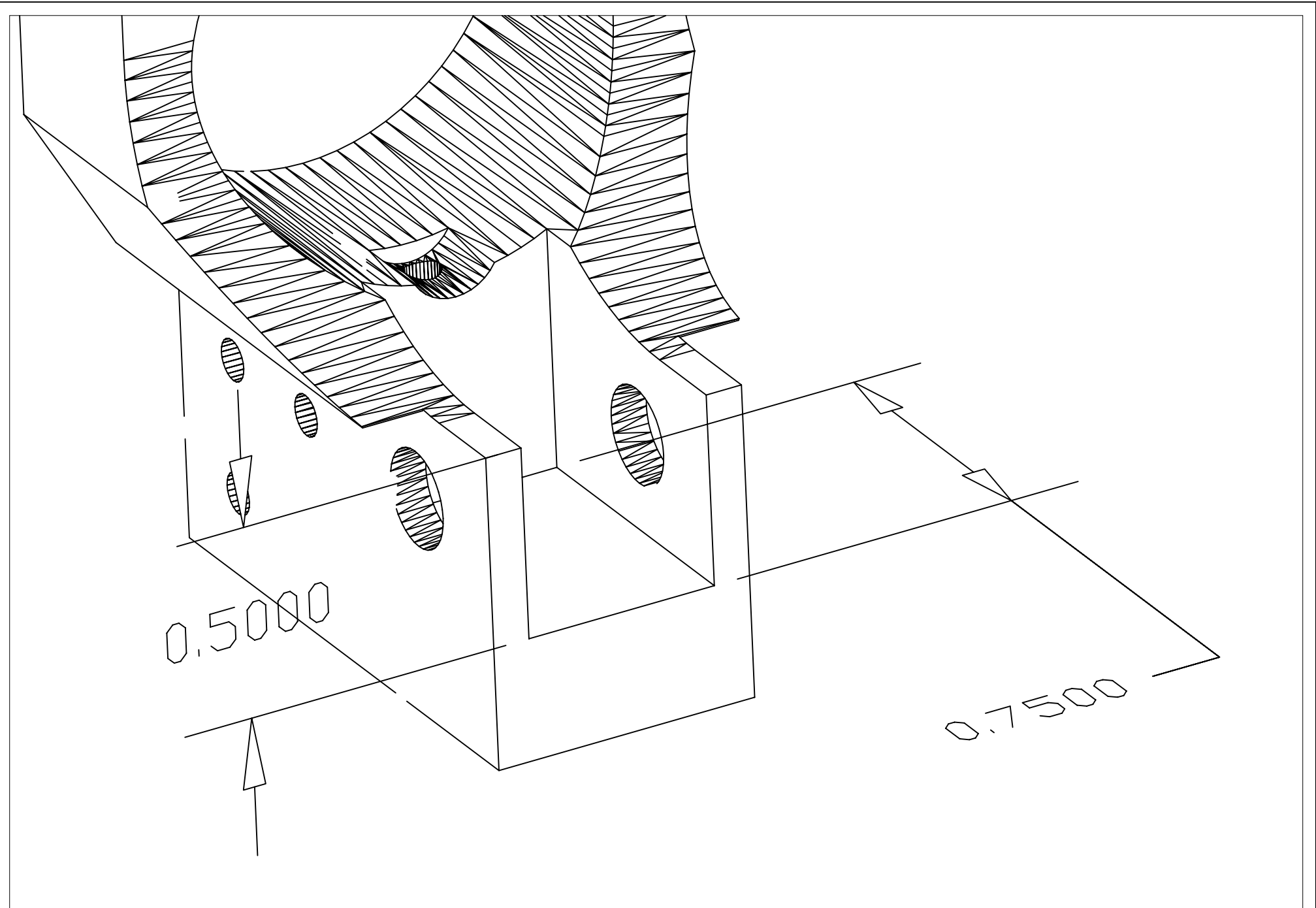

TITLE	AR15 receiver buffer	DATE	Dec 2002	REV	A
AUTHOR	Copyright: elmgrove1765@yahoo.com	SHEET	3		

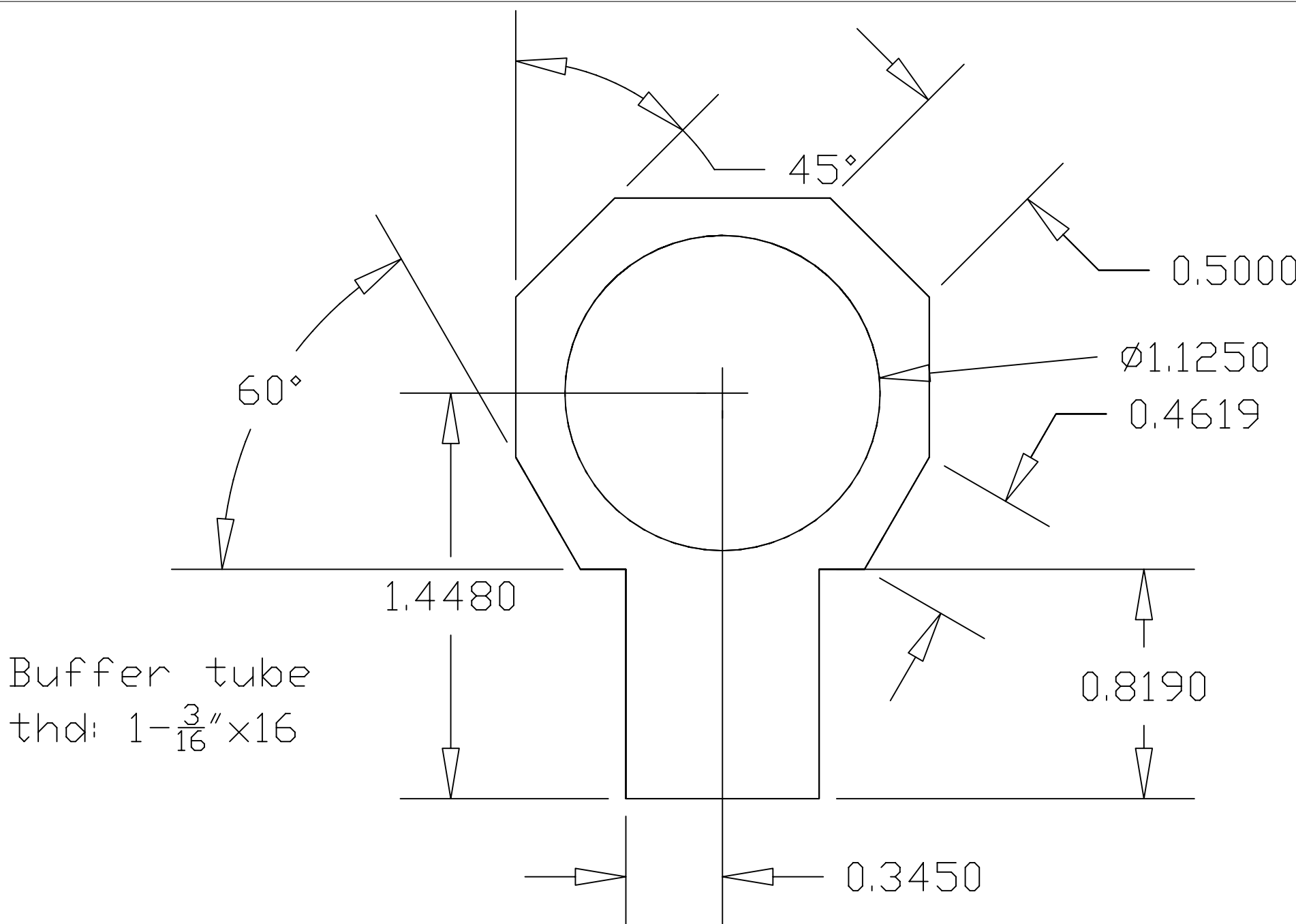

TITLE	AR15 receiver buffer	DATE	Dec 2002	REV	A
AUTHOR	Copyright: elmgrove1765@yahoo.com	SHEET	4		

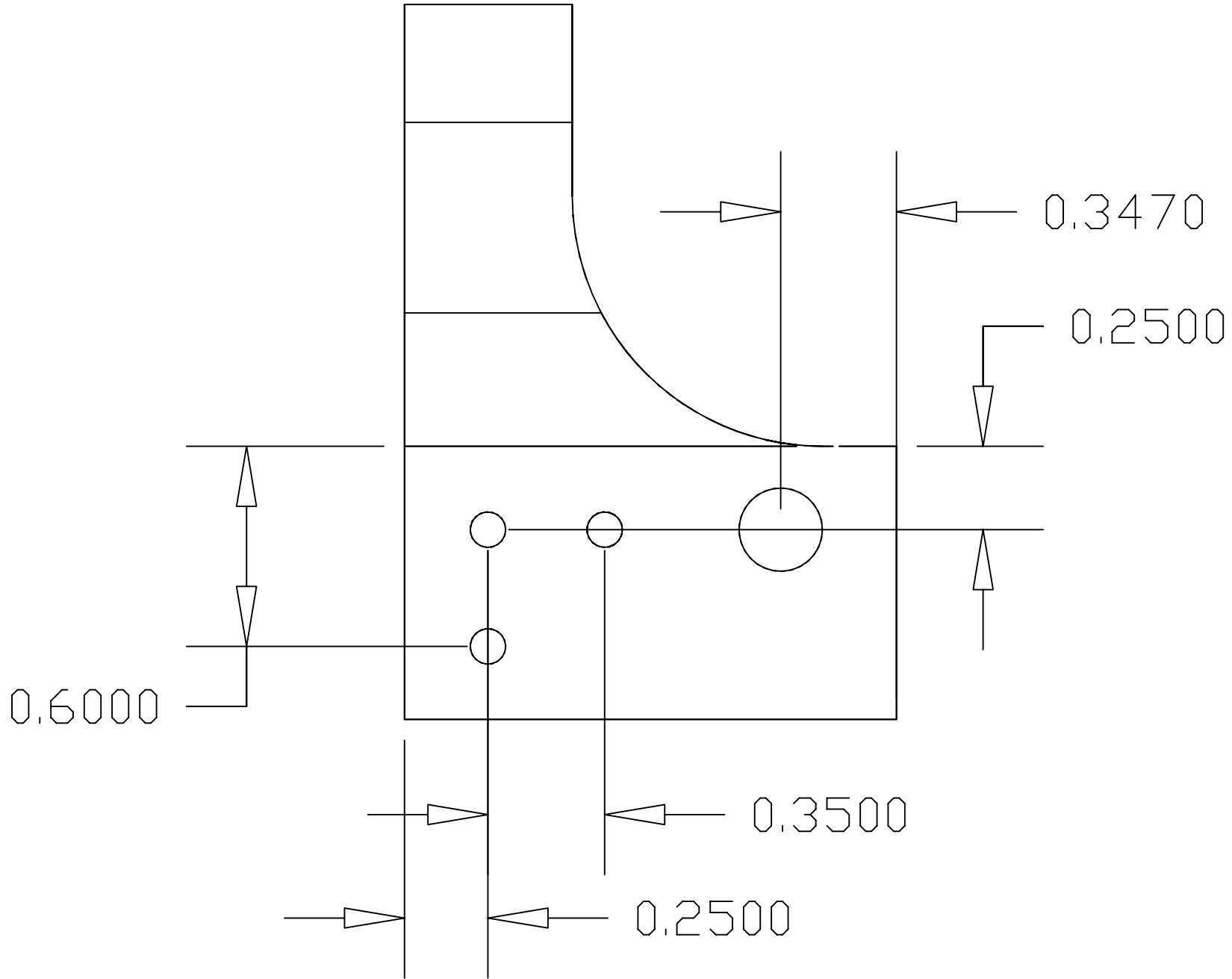

TITLE	AR15 receiver buffer	DATE	Dec 2002	REV	A
AUTHOR	Copyright: elmgrove1765@yahoo.com	SHEET	5		

Buffer retainer hole details

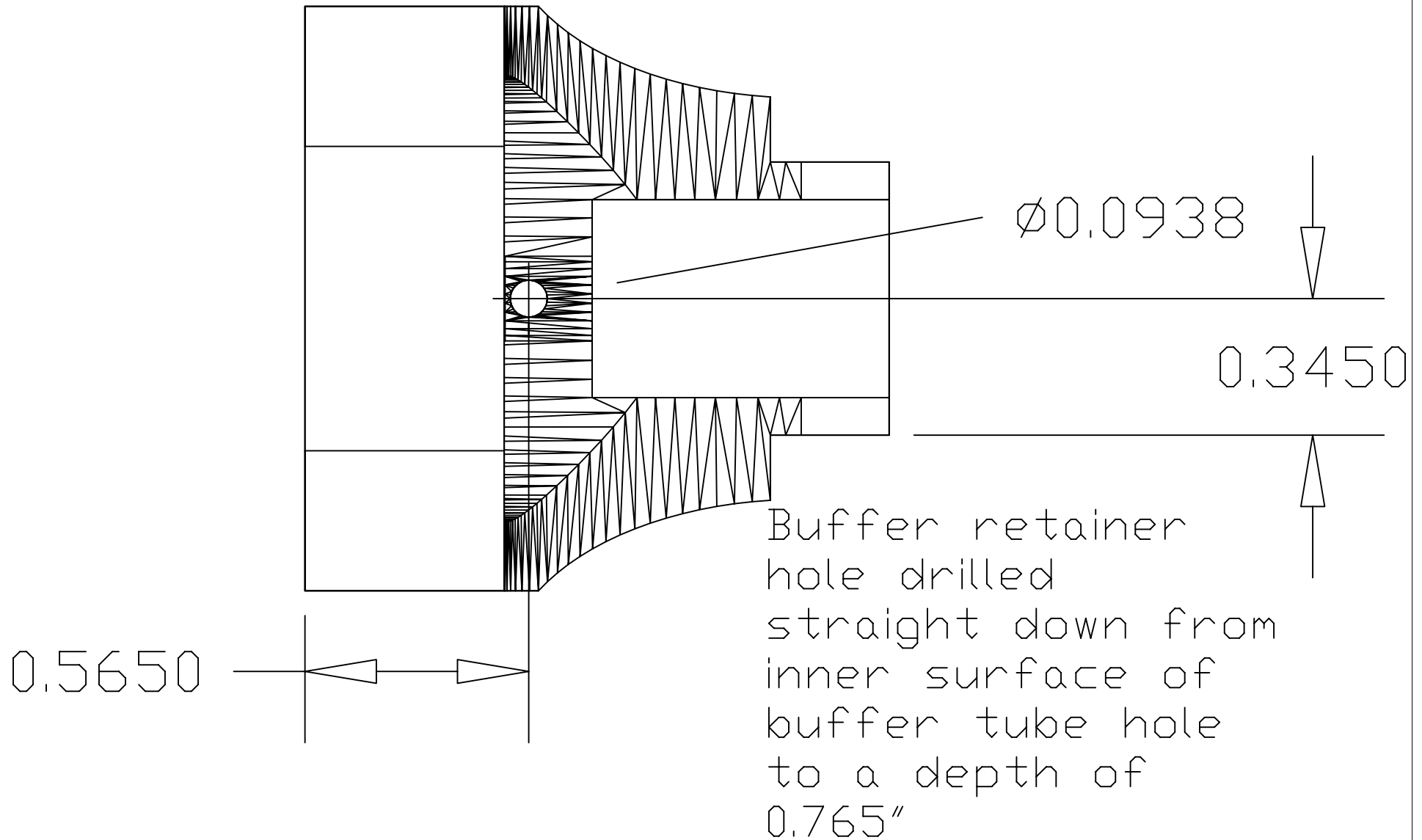

TITLE	AR15 receiver buffer	DATE	Dec 2002	REV	A
AUTHOR	Copyright: elmgrove1765@yahoo.com	SHEET	6		

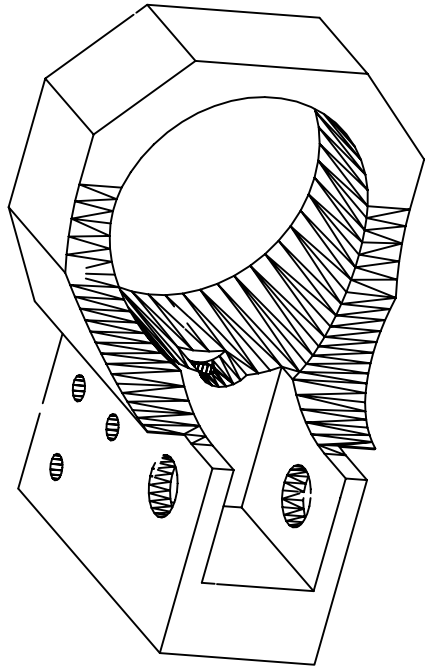

Note:

The buffer retainer hole was drilled after threading the buffer tube hole (mistake!). To make drilling this hole easier, the threads were milled off in a small area around the buffer retainer hole with a $\frac{1}{4}$ " diameter endmill (exact size is not critical but mill off enough material to just remove the thread (thread depth is approx. 0.065"). The the buffer retainer hole is drilled to a depth of 0.7" from the top surface of the small flat area.

To avoid this, drill the buffer retainer hole before tapping for the buffer tube (hole depth is 0.765" from inner surface of buffer tube hole - as stated on sheet 6)

TITLE	AR15 receiver buffer	DATE	Dec 2002	REV	A
AUTHOR	Copyright: elmgrove1765@yahoo.com	SHEET	7		

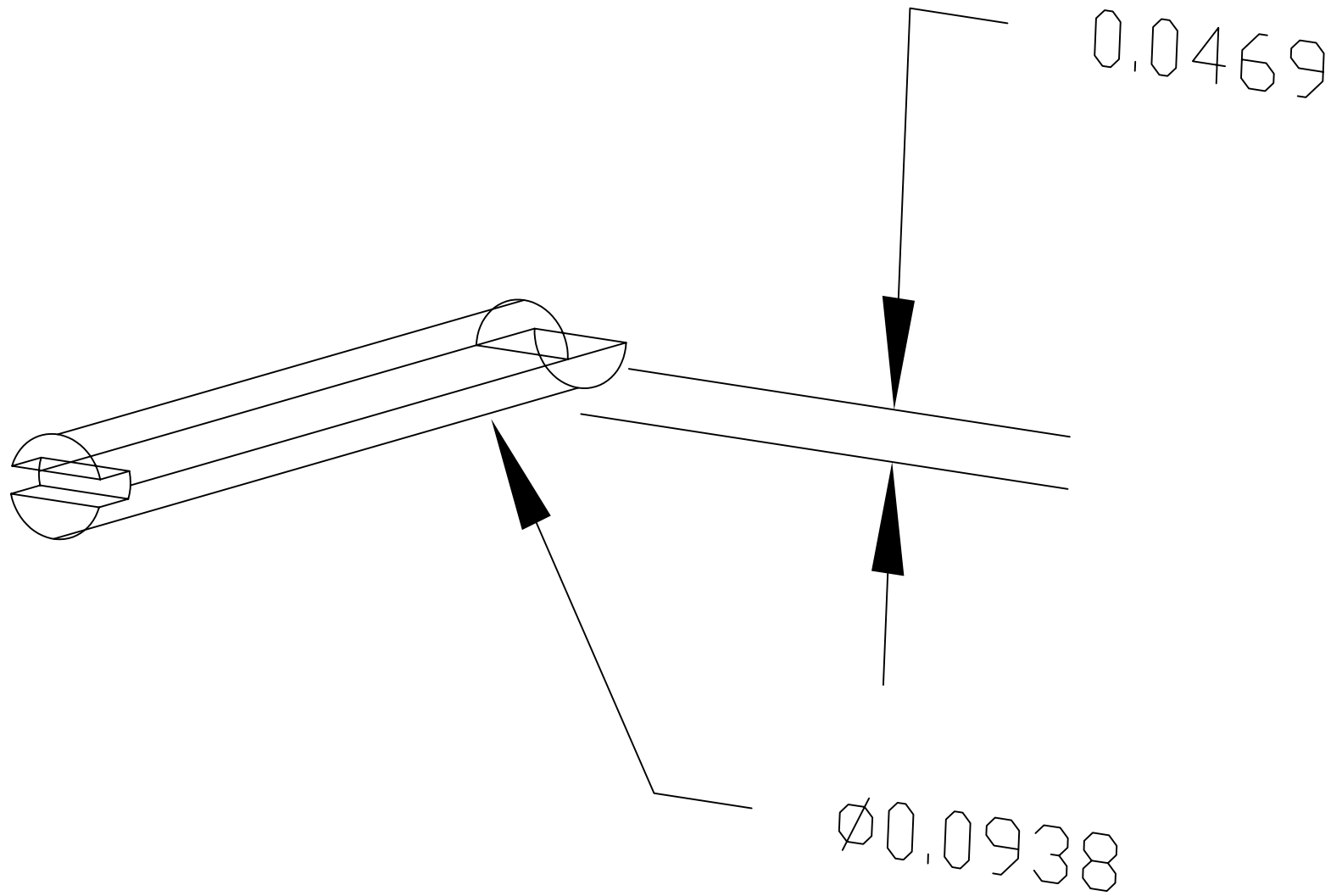

TITLE	AR15 receiver buffer retainer	DATE	Oct 2002	REV	A
AUTHOR	Copyright: elmgrove1765@yahoo.com	SHEET	0		

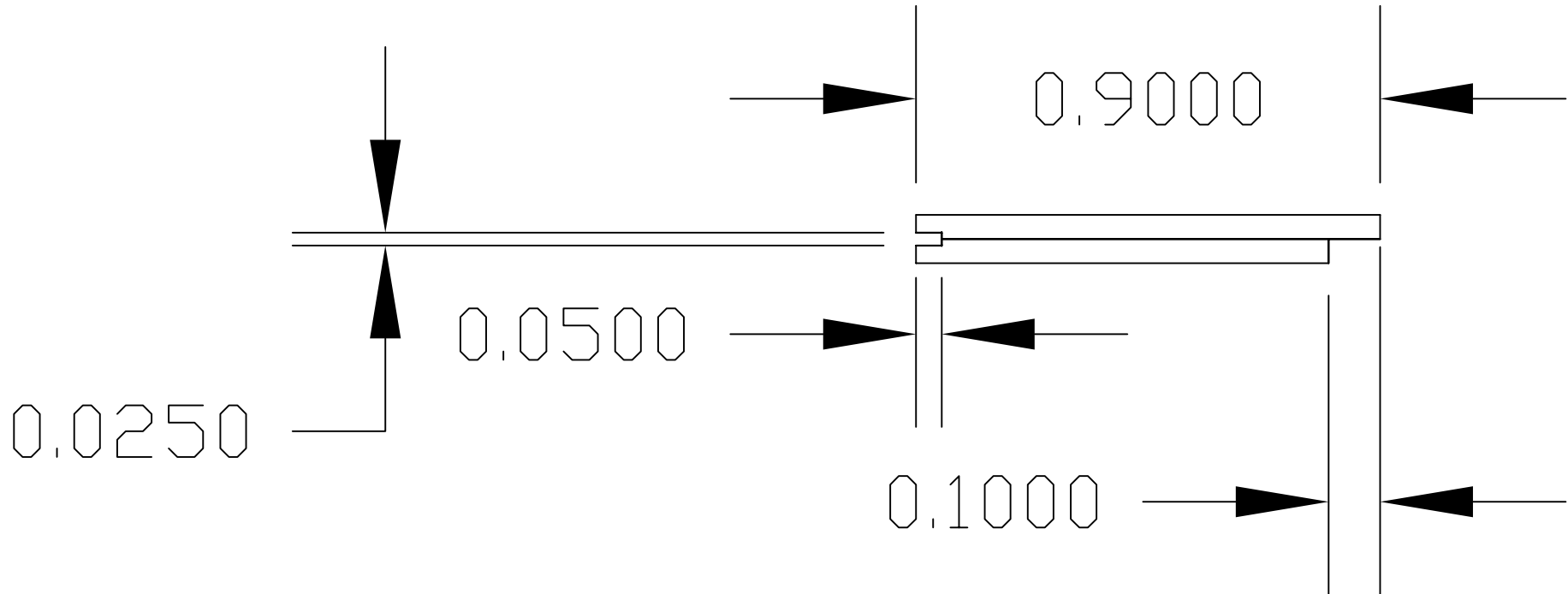

TITLE	AR15 receiver buffer retainer	DATE	Oct 2002	REV	A
AUTHOR	Copyright: elmgrove1765@yahoo.com	SHEET	1		

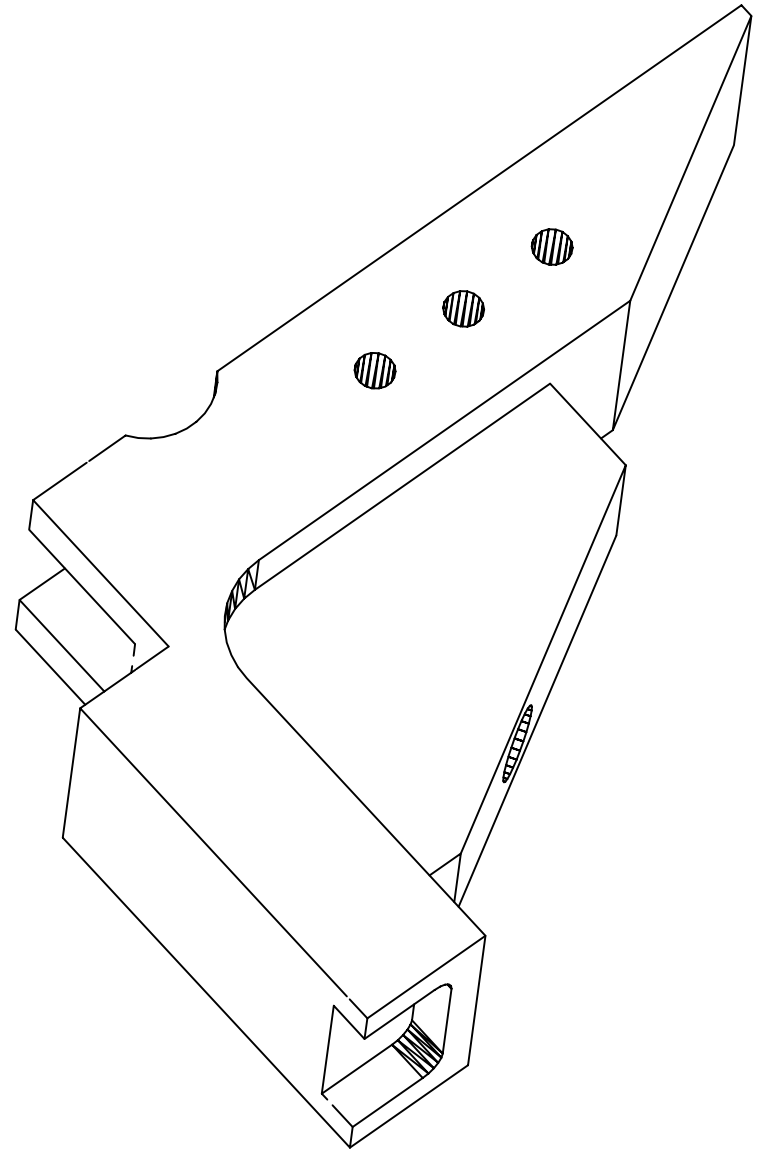
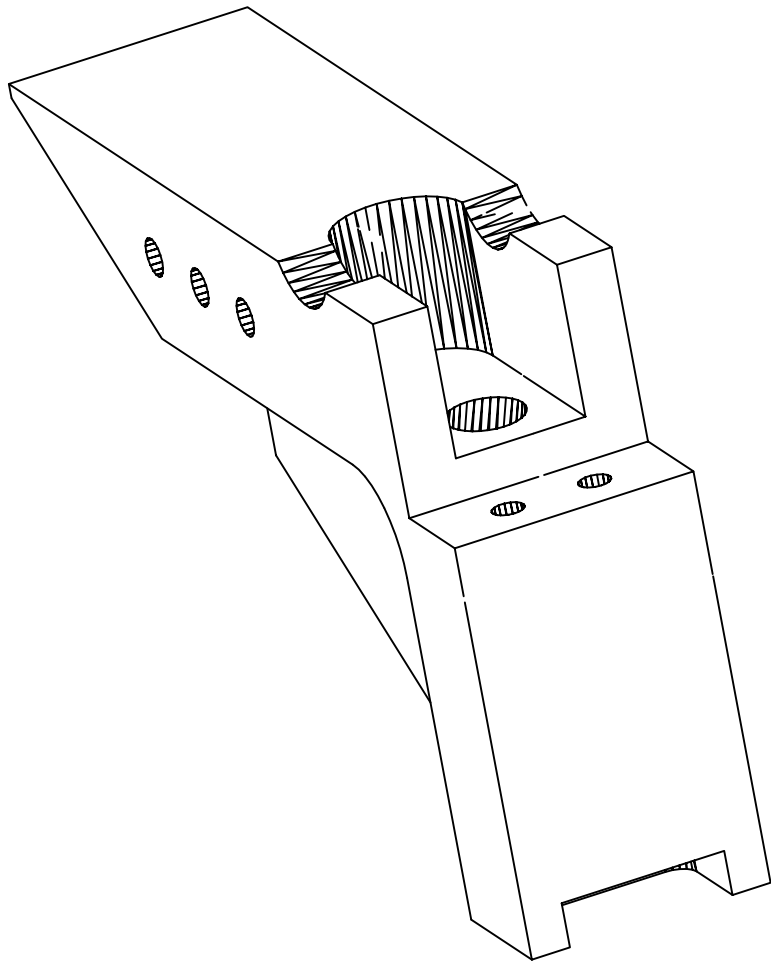

TITLE	AR15 receiver grip part	DATE	Dec 2002	REV	A
AUTHOR	Copyright: elmgrove1765@yahoo.com	SHEET	0		

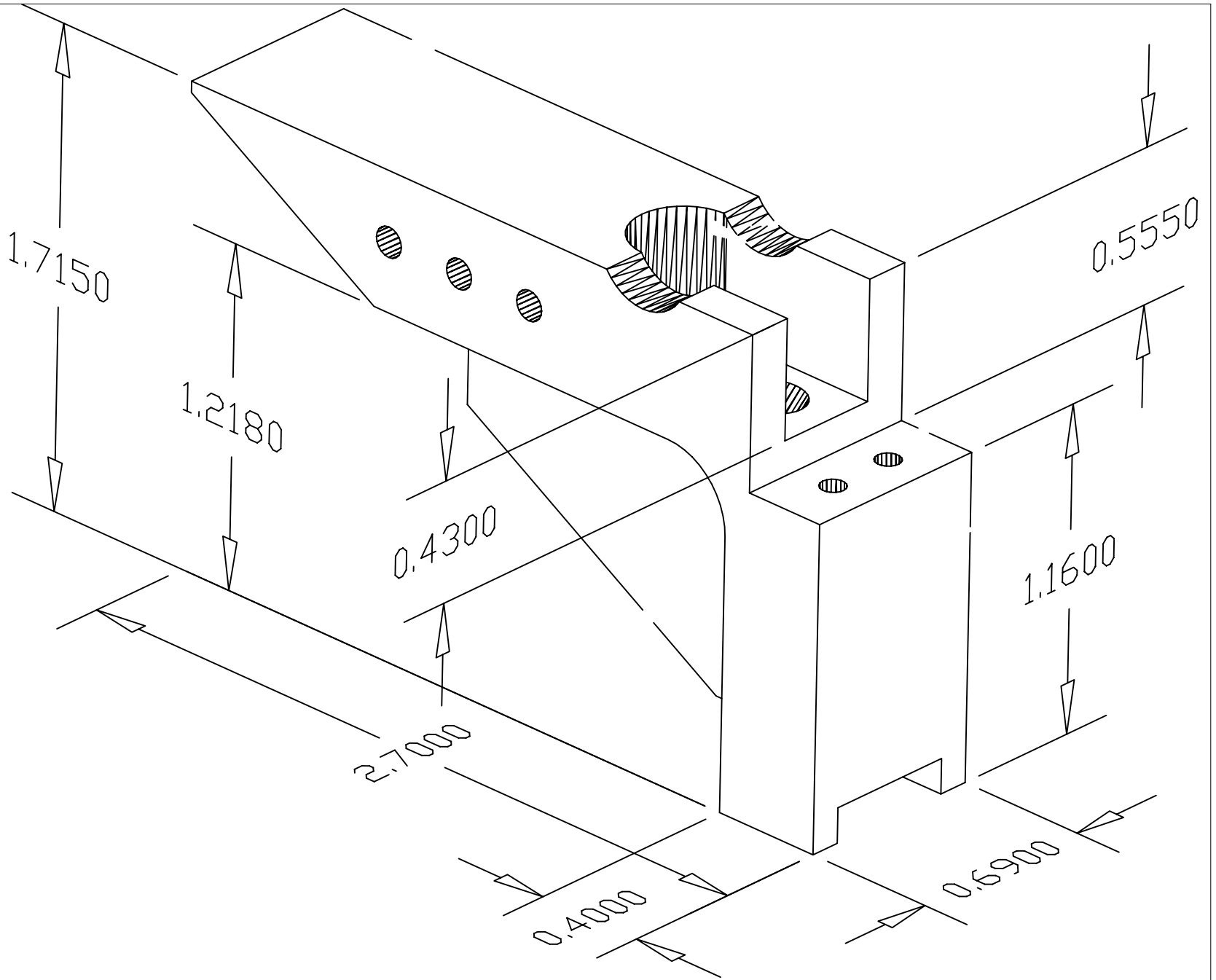

TITLE	AR15 receiver grip part	DATE	Dec 2002	REV	A
AUTHOR	Copyright: elmgrove1765@yahoo.com	SHEET	1		

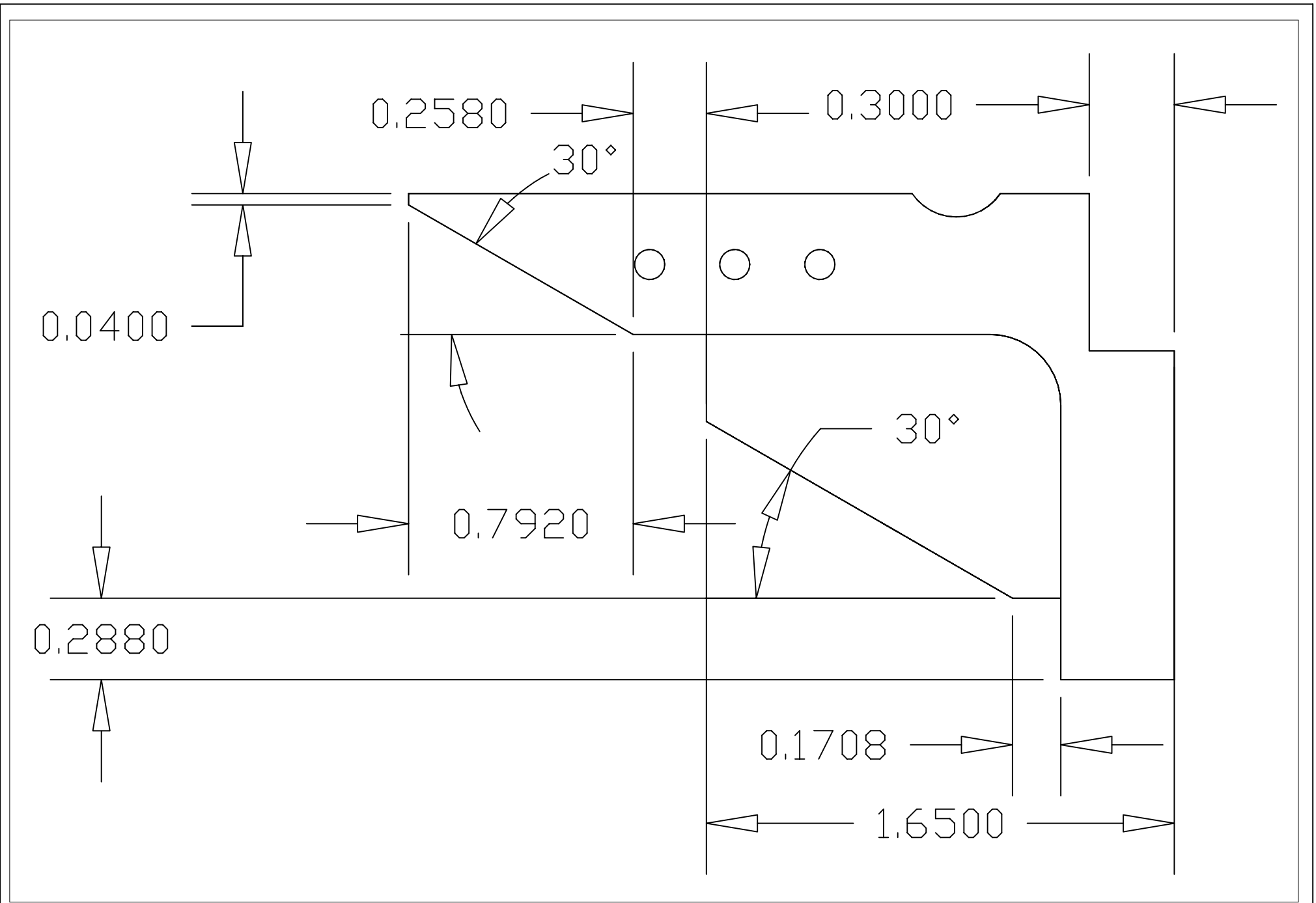

TITLE	AR15 receiver grip part	DATE	Dec 2002	REV	A
AUTHOR	Copyright: elmgrove1765@yahoo.com	SHEET	2		

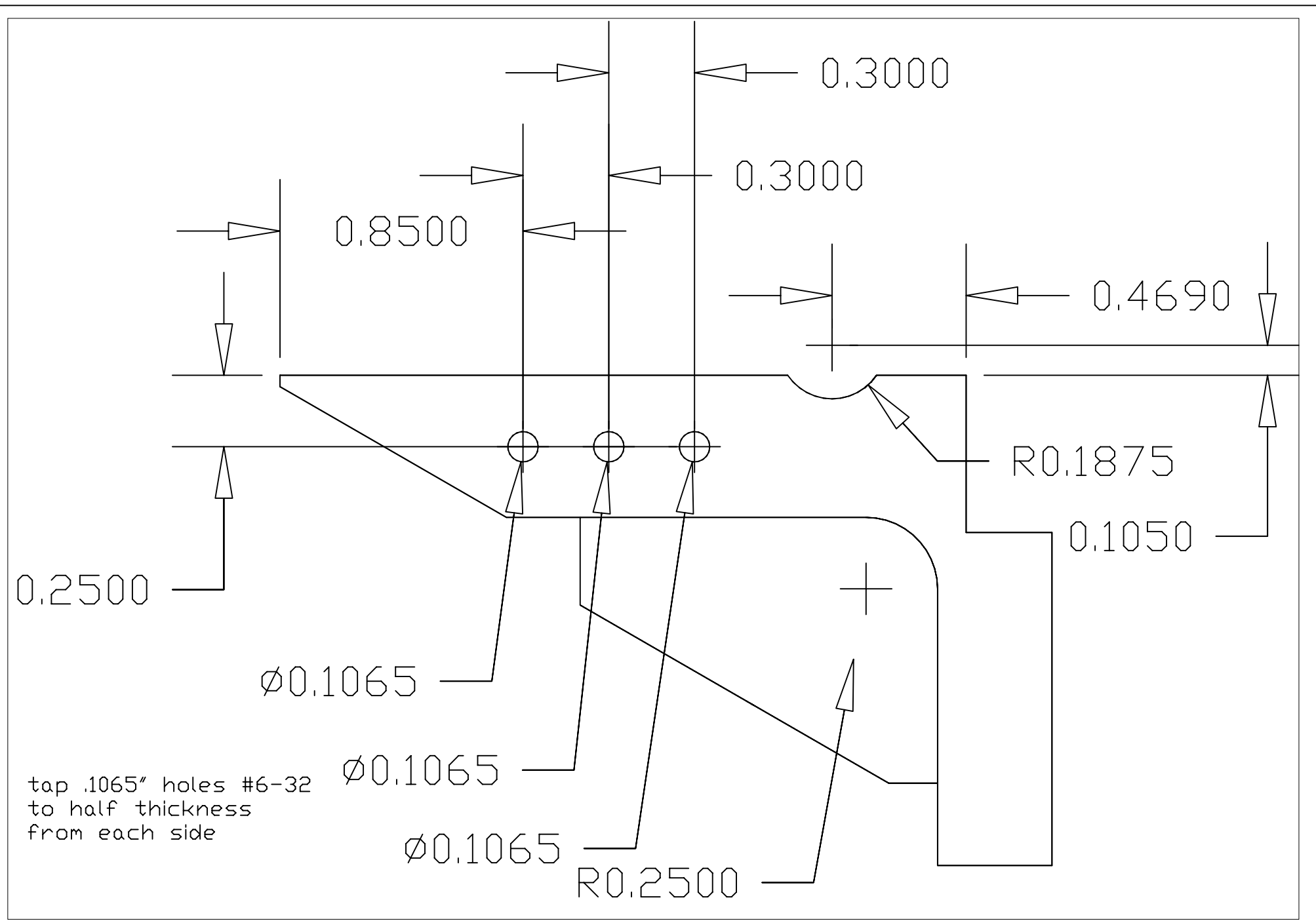

tap .1065" holes #6-32
to half thickness
from each side

TITLE	AR15 receiver grip part	DATE	Dec 2002	REV	A
AUTHOR	Copyright: elmgrove1765@yahoo.com	SHEET	3		

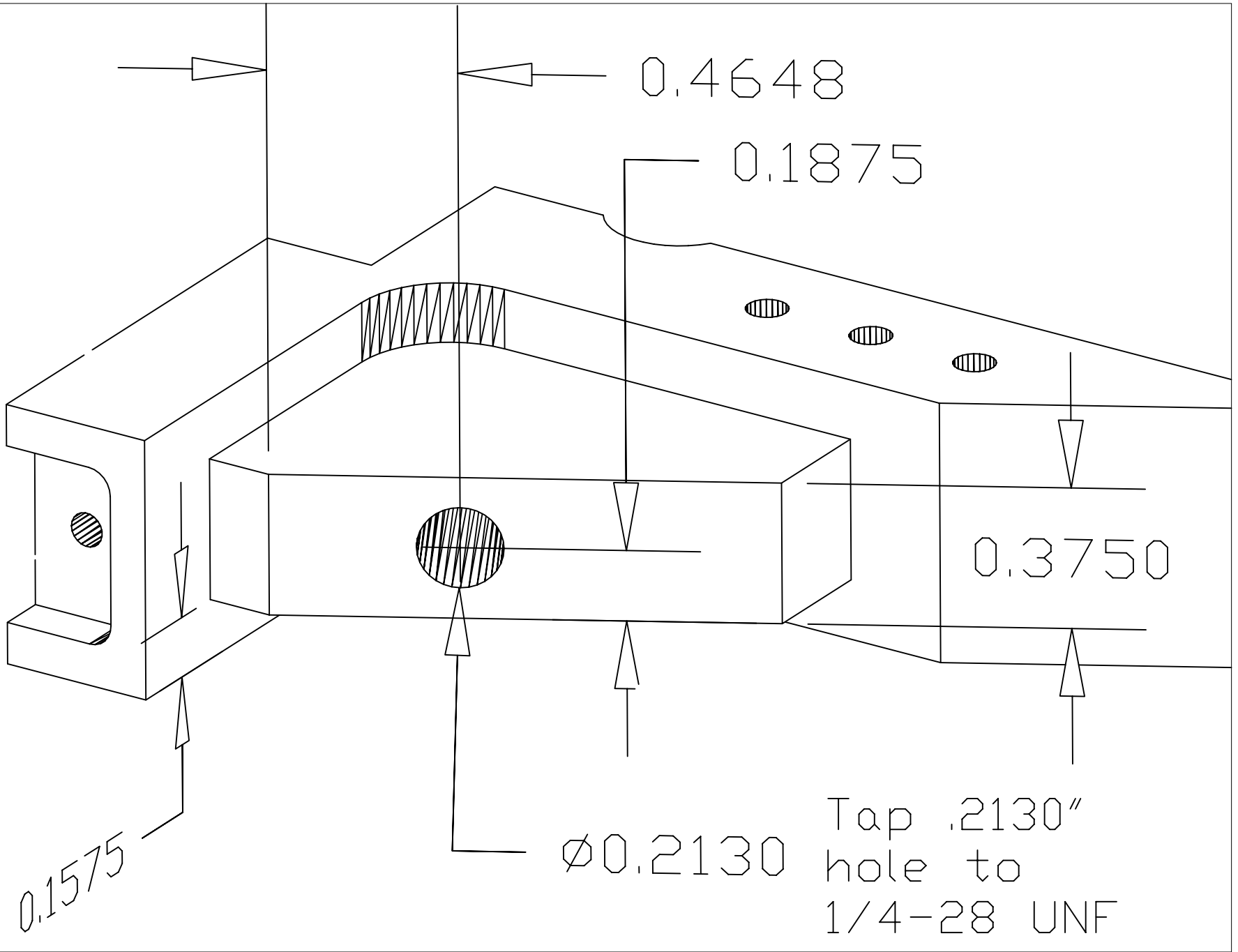

TITLE	AR15 receiver grip part	DATE	Dec 2002	REV	A
AUTHOR	Copyright: elmgrove1765@yahoo.com	SHEET	4		

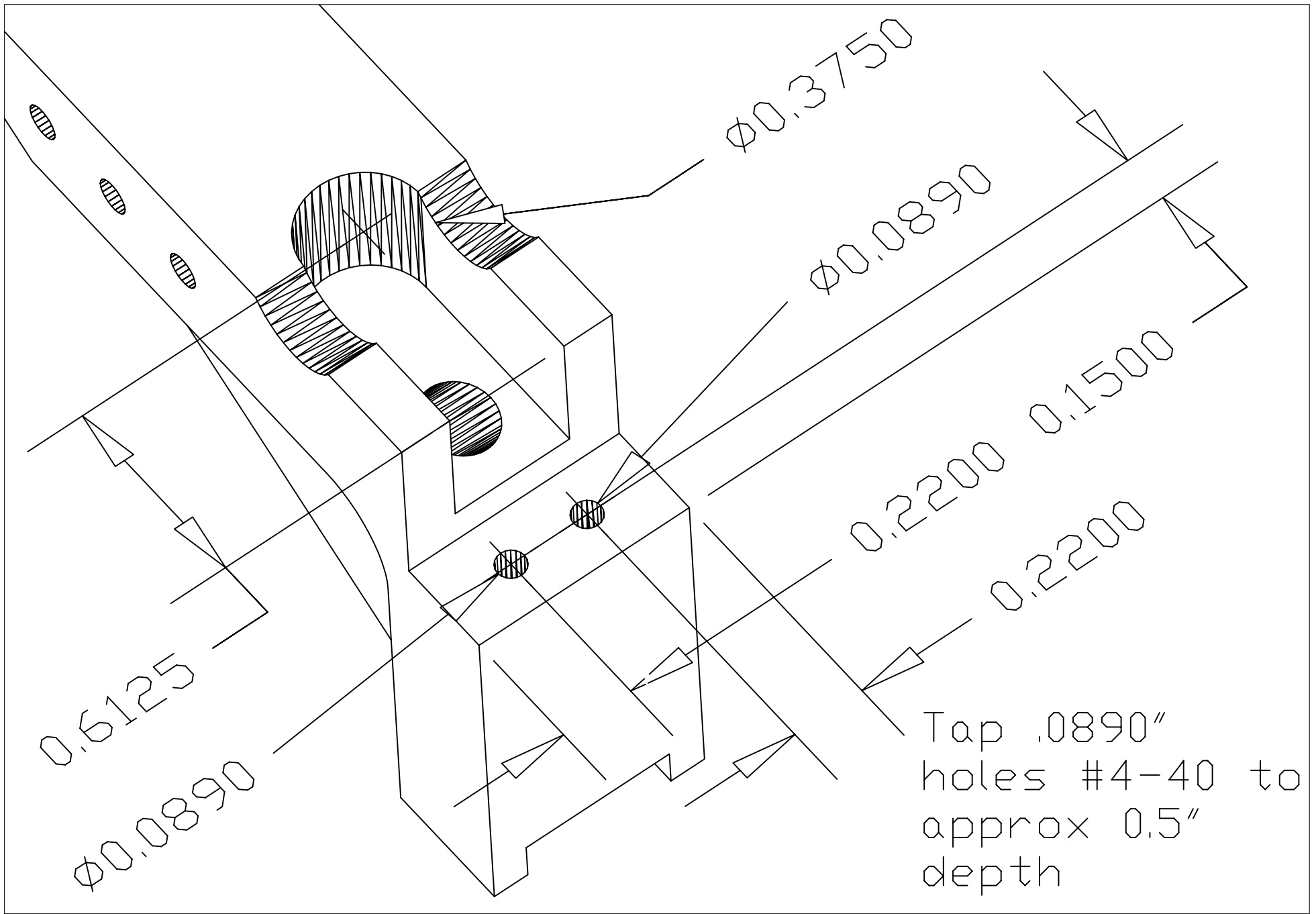

TITLE	AR15 receiver grip part	DATE	Dec 2002	REV	A
AUTHOR	Copyright: elmgrove1765@yahoo.com	SHEET	5		

Tap .089" hole
#4-40 to
approx. 0.5"
depth

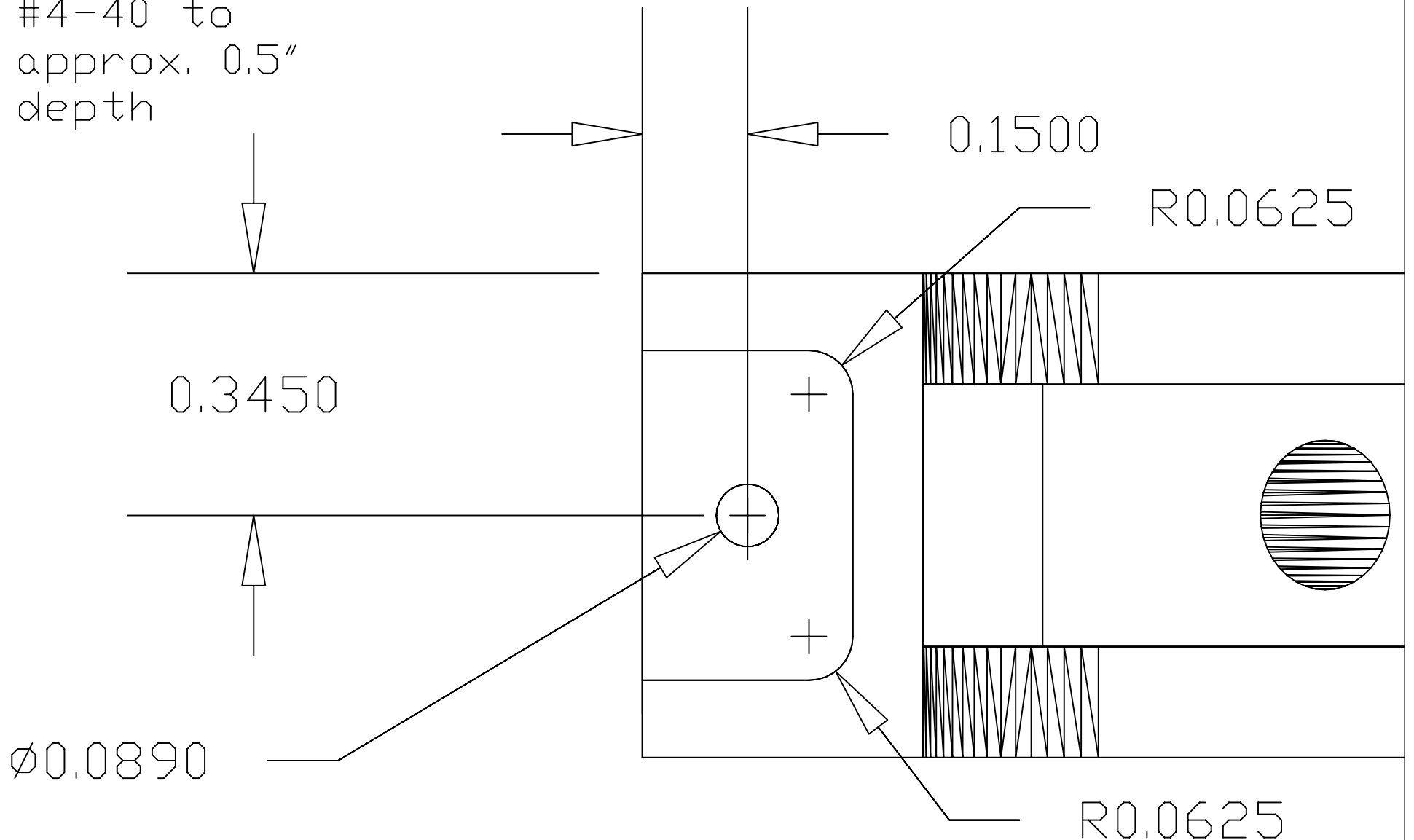

TITLE	AR15 receiver grip part	DATE	Dec 2002	REV	A
AUTHOR	Copyright: elmgrove1765@yahoo.com	SHEET	6		

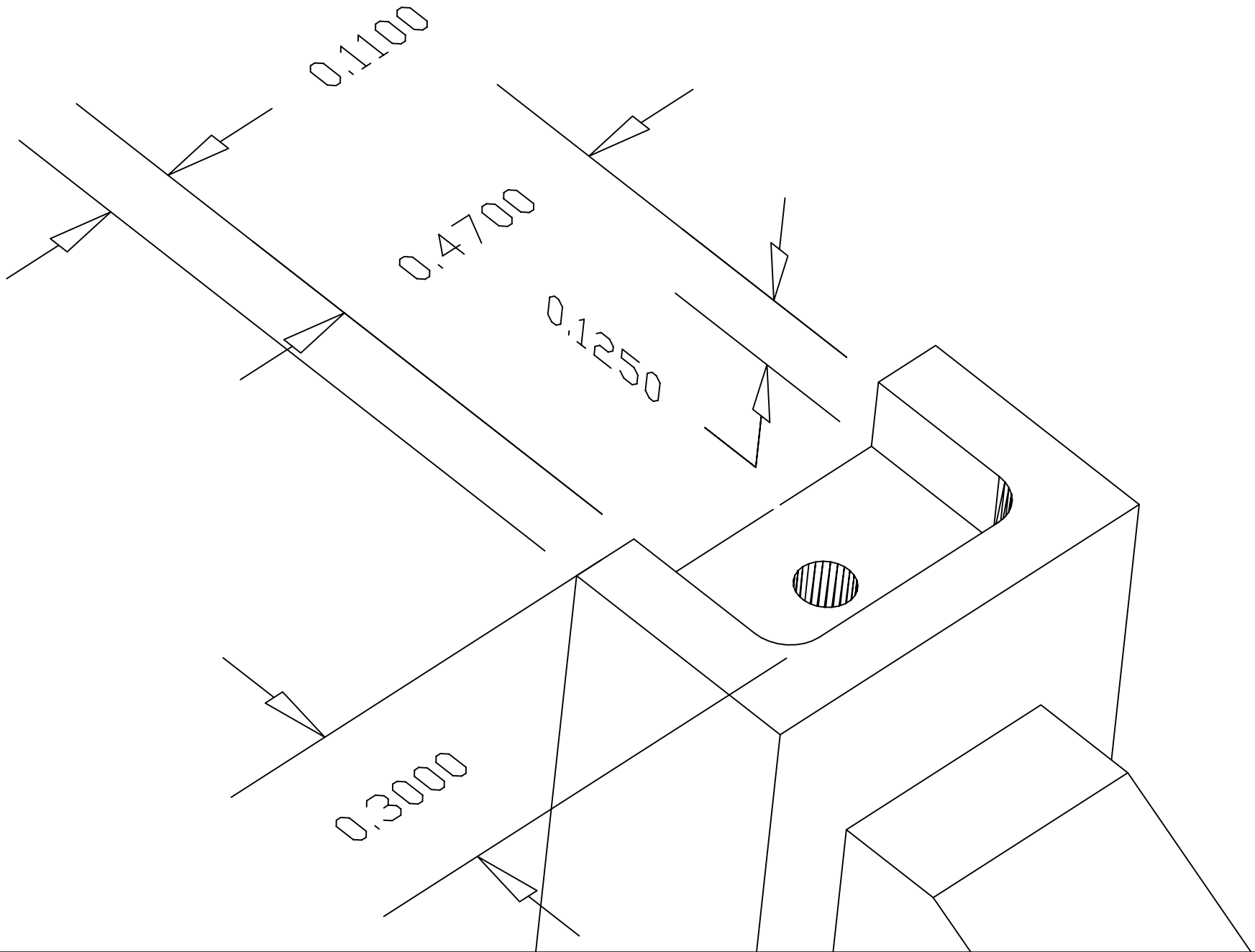

TITLE	AR15 receiver grip part	DATE	Dec 2002	REV	A
AUTHOR	Copyright: elmgrove1765@yahoo.com	SHEET	7		

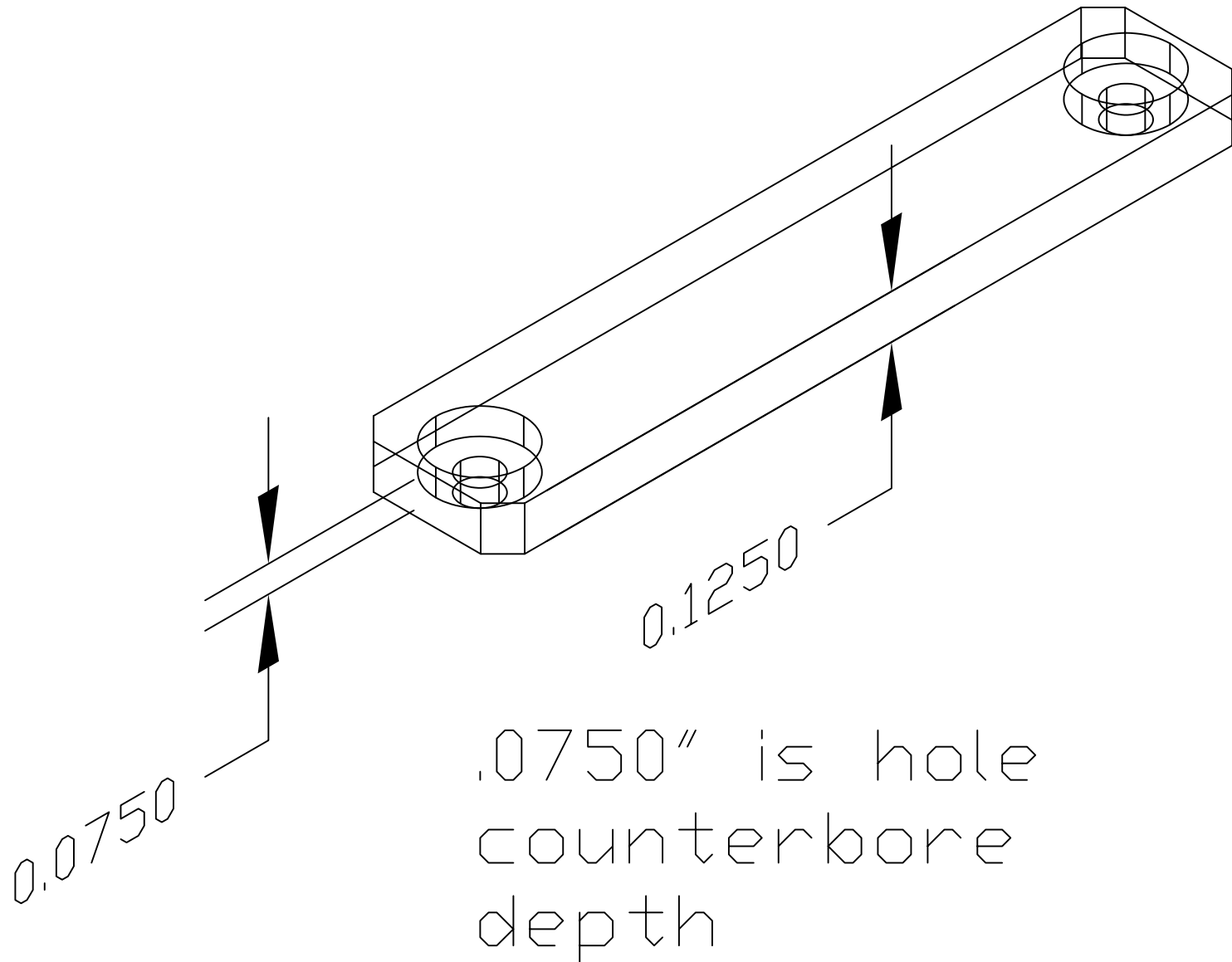

TITLE	AR15 receiver trigger guard	DATE	Oct 2002	REV	A
AUTHOR	Copyright: elmgrove1765@yahoo.com	SHEET	0		

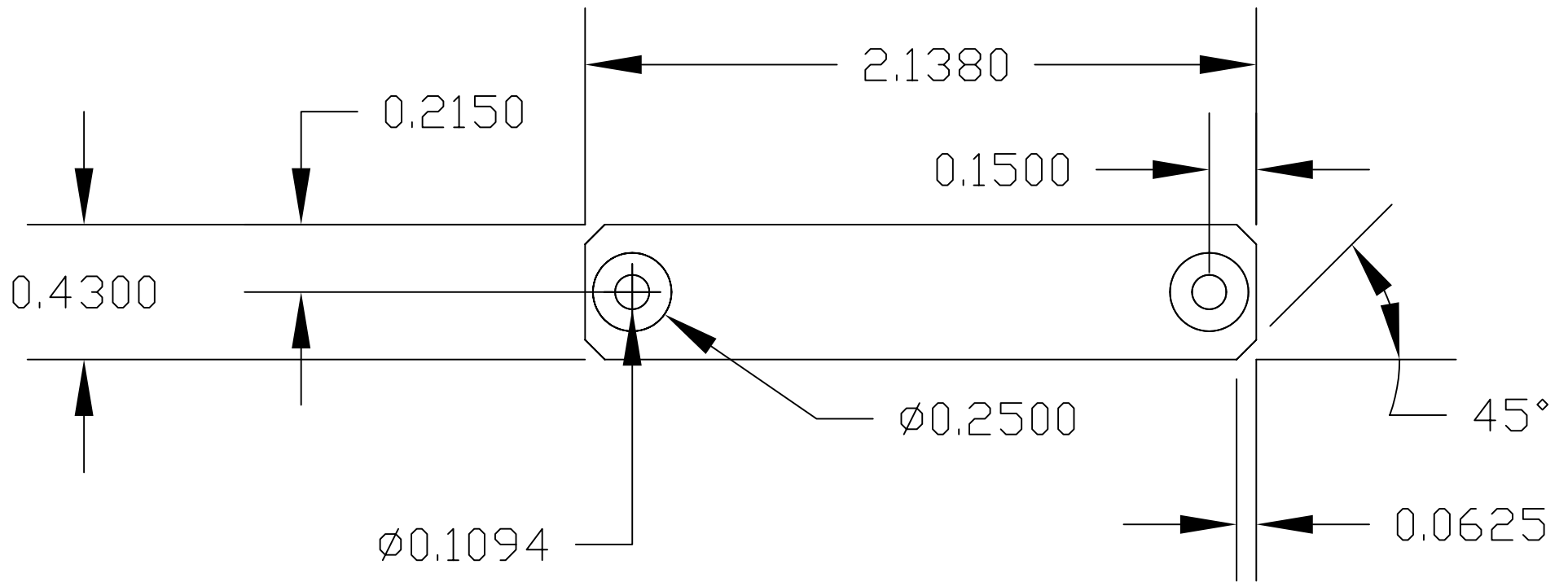

TITLE	AR15 receiver trigger guard	DATE	Oct 2002	REV	A
AUTHOR	Copyright: elmgrove1765@yahoo.com	SHEET	1		